

# Fisher™ 657 and 667 Diaphragm Actuators

Fisher 657 and 667 spring-opposed diaphragm actuators position the valve plug in the valve in response to varying controller or valve positioner pneumatic output signals applied to the actuator diaphragm. Zero setting of the actuator is determined by the compression of the actuator spring. Span is set by both the actuator spring rate and the number of springs available. The 657 actuator is direct-acting; the 667 is reverse-acting. These actuators are designed to provide dependable on-off or throttling operation of automatic control valves.

## Features

- **Application Versatility**—Five actuator types in eleven sizes are available for an extensive variety of applications. Spring rates, travel stops, and manual operators are available for nearly any control valve application.
- **Excellent Linearity Between Loading Pressure and Travel**—A molded diaphragm travels in a deep diaphragm casing, minimizing area change throughout the travel.
- **High Degree of Dynamic Stability and Frequency Response**—A shallow casing on the pressure side means reduced volume on that side, thereby minimizing response time.
- **High Thrust Capability**—The molded diaphragm allows maximum thrust for given diaphragm size.
- **Long Service Life**—Rugged thick-walled cast iron and steel construction provides increased stability, corrosion protection, and protection from deformation should over-pressurization occur.
- **Cold Service Applications**—Enhanced product specifications for all sizes of 657 and 667 diaphragm actuators allow performance to  $-50^{\circ}\text{C}$  ( $-58^{\circ}\text{F}$ ). Use of a positioner is recommended to ensure responsiveness in applications operating below  $-40^{\circ}\text{C}$  ( $-40^{\circ}\text{F}$ ).
- **Positive Connections**—A split block stem connection provides a solid transfer of motion while allowing easy mounting. The absence of linkages helps to avoid lost motion and inaccurate valve positioning.



W2174-2

657 ACTUATOR

W1916-3

667 ACTUATOR

Fisher 657 and 667 Actuators Mounted on  
easy-e™ Valves

Specifications

Standard Operating Pressure Range<sup>(1)</sup>

657 and 667: ■ 0.2 to 1.0 bar (3 to 15 psig) or ■ 0.4 to 2.0 bar (6 to 30 psig)
657-4 and 667-4: 0.2 to 1.9 bar (3 to 27 psig)
667 Size 76: ■ 0.4 to 2.0 bar (6 to 30 psig) or ■ 0 to 3.1 bar (0 to 45 psig)

Maximum Travel

See table 1

Output Indication

Stainless steel disk or pointer and graduated scale

Stroking Speed

Dependent on actuator size, travel, spring rate, initial spring compression, and supply pressure. If stroking speed is critical, consult your Emerson Process Management sales office



Maximum Allowable Thrust<sup>(2)</sup>

See table 1

Operating Temperature Range<sup>(1)</sup>

Standard Construction (Nitrile Elastomers): -40 to 82°C (-40 to 180°F)
Optional Construction (Silicone Diaphragm): -40 to 149°C (-40 to 300°F)
Maximum Valve Packing Box Temperature: 427°C (800°F) with cast iron yoke

Volumetric Displacement

See table 2

Signal Connections

Sizes 30 - 60 and 667 Size 76: 1/4 NPT internal
Sizes 70 and 87: 1/2 NPT internal
Size 80
657: 3/4 NPT internal with 1/4 NPT internal bushing
667: 1/2 NPT internal with 1/4 NPT internal bushing
Size 100: 1 NPT internal with 1/4 NPT internal bushing

Effective Diaphragm Area

See table 1

Construction Materials (refer to figure 1)

Diaphragm Casing

Sizes 30 - 87: Steel
Size 80: ■ Cast iron or ■ steel
Size 100: ■ Cast aluminum

Diaphragm

Sizes 30 - 87: ■ Nitrile on nylon, ■ Silicone on polyester
Size 100: Nitrile on polyester

Diaphragm Plate

657 Sizes 30-60, 100: ■ Cast aluminum
657 Sizes 70 - 87: ■ Cast iron or ■ steel
667 Sizes 30 - 60, 100: ■ Cast aluminum or ■ steel
667 Sizes 70 - 87: ■ Cast iron or ■ steel

Actuator Spring: Steel

Spring Adjustor: Steel

Spring Seat: ■ Steel or ■ cast iron

Actuator Stem: Steel

Travel Indicator: Stainless steel

O-Rings: Nitrile

Seal Bushing: Brass

Stem Connector: Zinc-plated steel

Yoke

Sizes 30 - 80: ■ Cast iron or ■ steel

Size 100: Steel

-continued-

Contents

Features . . . . . 1
Specifications . . . . . 2
Available Configurations . . . . . 3
Direct Action . . . . . 3
Reverse Action . . . . . 3
Accessories . . . . . 4
Handwheels . . . . . 4
Adjustable Travel Stops . . . . . 4
Other . . . . . 4
Ordering Information . . . . . 15

Tables
Additional Specifications . . . . . 6
Volumetric Casing Displacement . . . . . 7
Approximate Actuator Weights (without handwheel) . . . . . 7
Thrust Capabilities . . . . . 8
Handwheel Specifications . . . . . 11
Adjustable Travel Stop Styles . . . . . 12
Dimensions . . . . . 15

Specifications (continued)

**Construction Materials for Cold Service  
[to -50°C (-58°F)] 657 and 667--all sizes**

Yoke: Steel (Grade LCC)  
Diaphragm: Silicone  
O-Rings:<sup>(3)</sup> Ethylene Propylene  
Bolting: Stainless Steel B8M Cl 2  
Stem Connector: Stainless Steel  
Lubricant: Silicone

**Stem and Yoke Boss Diameters**

See table 1

**Approximate Weight**

See table 3

**Options**

■ Oversize signal connections, ■ Plastic yoke covers

1. The pressure and temperature limits in this bulletin and in any applicable standard or code limitation should not be exceeded.  
2. Do not exceed the thrust limits in this bulletin.  
3. Includes diaphragm casing seals, casing-mounted handwheel on 657, seal bushing on 667.

## Available Configurations

### Direct Action

All 657 actuators are direct acting. Applying air pressure to the upper diaphragm casing forces the actuator stem downward. When this pressure is reduced, the opposing spring force moves the actuator stem upward. Should the loading pressure fail, the spring forces the stem to the extreme upward position. This provides fail-open action for push-down-to-close valves and fail-closed action for push-down-to-open valves.

**657**—A direct-acting actuator used on sliding-stem valves. Available in sizes 30 through 100. See figures 1, 2, 5, and 6.

**657-4**—A 657 actuator in sizes 70 and 87, designed with 102 mm (4-inch) travel.

### Reverse Action

All 667 actuators are reverse acting. Applying air pressure to the lower diaphragm casing forces the actuator stem upward against the opposing spring force. When this loading pressure is reduced, the spring moves the actuator stem downward. Should the loading pressure fail, the spring forces the stem to the extreme downward position. The actuators provide fail-closed action for push-down-to-close valves and fail-open action for push-down-to-open valves.

**667**—A reverse-acting actuator used on sliding-stem valves. Available in sizes 30 through 100 and 76. See figures 1, 2, and 7.

**667-4**—A 667 actuator in sizes 70 and 87, designed with 102 mm (4-inch) travel.

## Accessories

### Handwheels

Handwheels for diaphragm actuators are often used as adjustable travel stops. They also provide a ready means of positioning the control valve in an emergency. The specifications in tables 5 and 6 apply to handwheels on both 657 and 667 Series actuators. For repeated or daily manual operation, the unit should be equipped with a side-mounted handwheel actuator.

**Top-Mounted Handwheels**—Typical 657 and 667 actuators with handwheels mounted on the diaphragm case are shown in figure 2 (not available on a 667 actuator, size 80). On the 657 actuator, the handwheel can be set to limit the travel in the upward direction; on the 667 actuator, travel in the downward direction can be restricted. A P-2 travel stop (figure 4) is available for a 667 actuator, sizes 45-60 to limit travel in either the upward or downward directions. An actuator with a P-2 travel stop is limited to a maximum travel of 19 mm (0.75 inch). The handwheel on the size 100 is similar in function to those on the smaller sizes, but it uses a gear drive similar to the drive employed on the integral side-mounted handwheels (see figure 2).

Clockwise rotation of the handwheel on the 657 actuator moves the actuator stem downward, compressing the spring. Spring action returns the stem as the handwheel is turned counterclockwise. With the 667 actuator, counterclockwise rotation moves the stem upward, and spring action returns the stem on clockwise rotation.

**Side-Mounted Handwheels**—Figure 3 shows the side-mounted handwheels (designated by the letters MO) applicable to sizes 34 through 87, 657 and 667 actuators. Size 30 actuators do not have a side-mounted handwheel available.

All side-mounted handwheels can be used to stroke the valve in either direction at any point in the actuator stem travel. Unlike the top-mounted handwheel, the side-mounted handwheel can be positioned to limit travel in either direction, but not both at the same time. With the handwheel in the neutral position, automatic operation is possible throughout full valve travel. In any other position, valve travel will be restricted. The handwheel is furnished with a spring-loaded ball detent which prevents vibration from changing the setting.

### Adjustable Travel Stops

Top-mounted adjustable travel stops are available for 657 and 667 Series actuators. They are used to limit travel in the up, down, or up and down directions. Figure 4 illustrates the different constructions. Table 7 locates the different style constructions with actuator type and use.

### Other

Accessories such as transducers, positioners, position transmitters, air relays, volume boosters, switching valves, lockup valves, limit switches, and solenoid valves are also available for actuator mounting. They are described in separate publications. Contact your [Emerson Process Management sales office](#) for details.

Figure 1. Typical Actuators

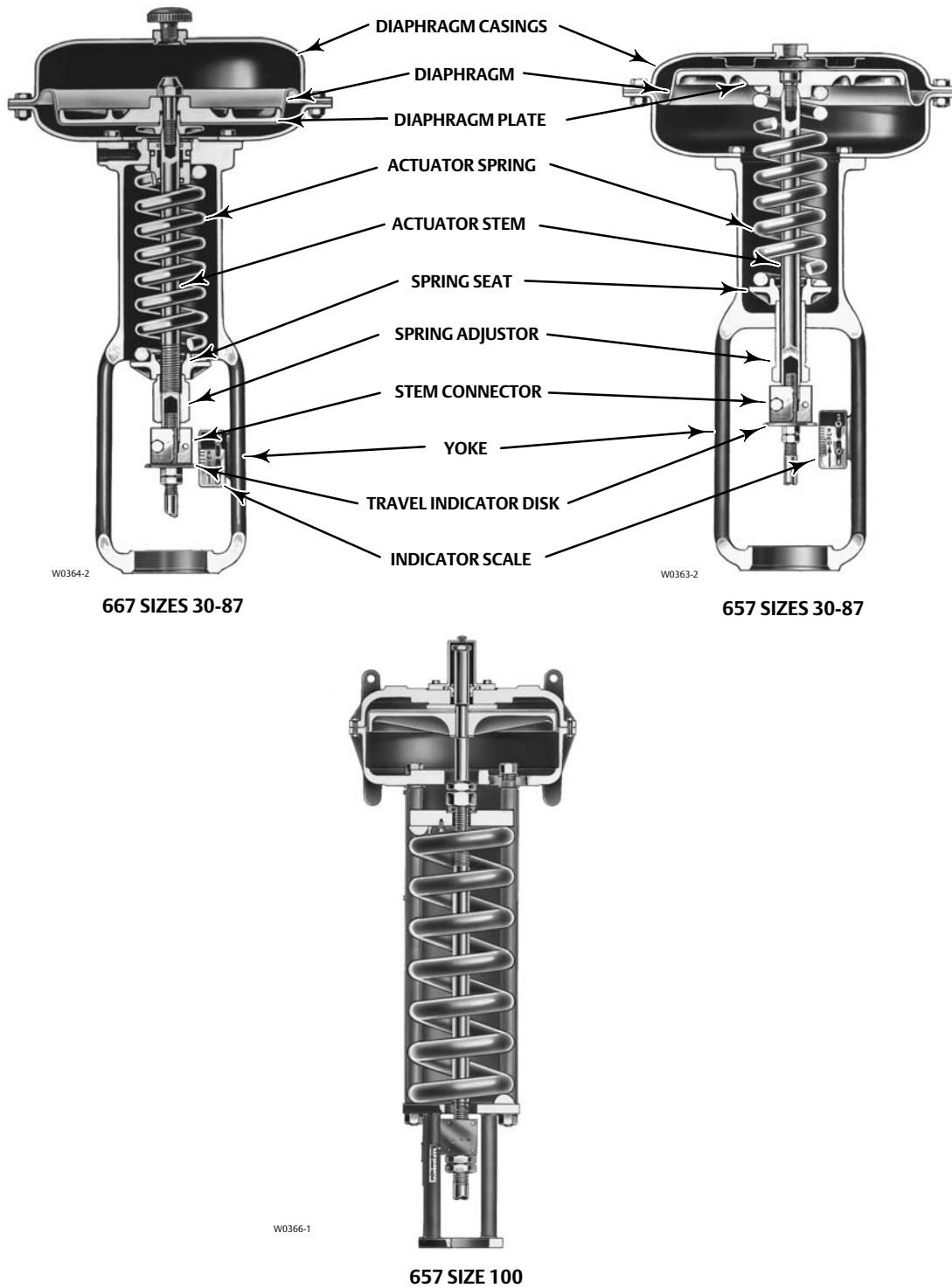

**Table 1. Additional Specifications for Fisher 657 and 667 Series Actuators**

ACTUATOR SIZE	EFFECTIVE DIAPHRAGM AREA	YOKE BOSS DIAMETER	STEM DIA	MAXIMUM TRAVEL	MAXIMUM ALLOWABLE THRUST <sup>(1)</sup>
	cm <sup>2</sup>	mm			N
30	297	54	9.5	19	10,231
34	445	54	9.5	29	10,231
40	445	71	12.7	38	12,010
45	677	71	12.7	51	25,132
46	1006	71	12.7	51	33,584
50	677	90	19.1	51	25,131
60	1006	90	19.1	51	30,246
70 <sup>(2)</sup>	1419	90	19.1	76	39,142
				102 <sup>(3)</sup>	
76(667)	1006	90	19.1	51	30,246
80	1761	127	25.4	76	63,392
			31.8		88,075 <sup>(4)</sup>
87 <sup>(2)</sup>	1419	127	25.4	76	39,142
				102 <sup>(3)</sup>	
100	2902	127H <sup>(5)</sup>	31.8	102	200,160
		178	50.8		
	Inch <sup>2</sup>	Inch			Lb
30	46	2-1/8	3/8	0.75	2300
34	69	2-1/8	3/8	1.125	2300
40	69	2-13/16	1/2	1.5	2700
45	105	2-13/16	1/2	2	5650
46	156	2-13/16	1/2	2	7550
50	105	3-9/16	3/4	2	5650
60	156	3-9/16	3/4	2	6800
70 <sup>(2)</sup>	220	3-9/16	3/4	3	8800
				4 <sup>(3)</sup>	
76(667)	156	3-9/16	3/4	2	6800
80	273	5	1	3	14,150
			1-1/4		19,800 <sup>(4)</sup>
87 <sup>(2)</sup>	220	5	1	3	8800
				4 <sup>(3)</sup>	
100	450	5H <sup>(5)</sup>	1-1/4	4	45,000
		7	2		

1. These values are based on material limitations such as yoke, stem connection, diaphragm plate, and travel stop strengths.  
 2. Values also apply to 657-4 and 667-4 actuators.  
 3. For 657-4 and 667-4 actuator constructions.  
 4. Steel construction.  
 5. H=Heavy actuator-to-valve bolting.

**Table 2. Volumetric Casing Displacement for Fisher 657 and 667 Series Actuators**

ACTUATOR SIZE	CLEARANCE VOLUME <sup>(1)</sup> cm <sup>3</sup>	TRAVEL, mm								
		11	16	19	29	38	51	76	102	
		Casing Volume <sup>(2)</sup> , cm <sup>3</sup>								
30	540	918	1080	1180	---	---	---	---	---	
34 and 40	934	1470	1700	1850	2330	2790	---	---	---	
45 and 50	1560	---	2790	3000	3720	4420	5410	---	---	
46, 60, and 76	2180	---	3880	4210	5280	6340	7740	---	---	
70 and 87	3490	5240	5950	6420	7830	9240	11,110	14,880	18,570	
80	4820	---	---	---	10,490	12,450	14,860	19,340	---	
100	657	10,880	---	---	16,400	19,170	21,940	25,630	33,000	40,380
	667	12,780	---	---	18,320	21,070	23,840	27,530	34,900	42,280
ACTUATOR SIZE	CLEARANCE VOLUME <sup>(1)</sup> Inch <sup>3</sup>	TRAVEL, INCH								
		0.4375	0.625	0.75	1.125	1.5	2	3	4	
		Casing Volume <sup>(2)</sup> , Inch <sup>3</sup>								
30	33	56	66	72	---	---	---	---	---	
34 and 40	57	90	104	113	142	170	---	---	---	
45 and 50	95	---	170	183	227	270	330	---	---	
46, 60, and 76	133	---	237	257	322	387	472	---	---	
70 and 87	213	320	363	392	478	564	678	980	1133	
80	294	---	---	---	640	760	907	1180	---	
100	657	664	---	---	1002	1170	1339	1564	2014	2464
	667	780	---	---	1118	1286	1455	1680	2130	2580

1. Clearance volume indicates casing volume at zero travel.  
2. Includes clearance volume.

**Table 3. Approximate Actuator Weights (without handwheel)**

ACTUATOR SIZE	ACTUATOR			
	657	667	657	667
	Kg		Lb	
30	16	15	36	34
34	22	22	48	48
40	23	23	51	50
45	37	41	82	90
46	49	55	107	121
50	42	43	92	94
60	53	55	116	122
70	107	115	235	254
76	---	86	---	190
80	234	284	515	626
87	116	118	255	260
100	346	544	762	1200

Table 4. Thrust Capabilities<sup>(1)</sup> by Input Signal Range

TRAVEL	ACTUATOR SIZE	PRESSURE RANGE TO ACTUATOR DIAPHRAGM <sup>(2)</sup>	THRUST CAPABILITIES	
			657	667
mm		Bar	N	
19	30	0.2-1	2250	1840
		0.4-2	3890	3270
	34	0.2-1	3380	3380
		0.4-2	5830	5530
29	40	0.2-1	3380	2760
		0.4-2	5530	3680
	45	0.2-1	4670	4670
		0.4-2	8410	8870
	46	0.2-1	6940	6250
		0.4-2	13,190	11,800
38	50	0.2-1	5140	3740
		0.4-2	8410	7010
	60	0.2-1	6940	4860
		0.4-2	13,190	8330
51	70	0.2-1	7830	7830
		0.4-2	18,590	13,700
	80	0.2-1	10,110	11,250
		0.4-2	18,950	19,680
	87	0.2-1	6850	7830
		0.4-2	18,590	13,700
76	100	0.2-1	16,010	8010
102		0.4-2	32,030	36,030
		0.2-1	12,010	---
		0.4-2	22,019	28,024
Inch		Psig	Lb	
0.75	30	3-15	506	414
		6-30	874	736
	34	3-15	759	759
		6-30	1311	1242
1.125	40	3-15	759	621
		6-30	1242	828
	45	3-15	1050	1050
		6-30	1890	1995
	46	3-15	1560	1404
		6-30	2964	2652
1.5	50	3-15	1155	840
		6-30	1890	1575
	60	3-15	1560	1092
		6-30	2964	1872
2	70	3-15	1760	1760
		6-30	4180	3080
	80	3-15	2272	2528
		6-30	4260	4424
	87	3-15	1540	1760
		6-30	4180	3080
3	100	3-15	3600	1800
4		6-30	7200	8100
		3-15	2700	---
		6-30	4950	6300

1. For Size 76 667 actuators, contact your [Emerson Process Management sales office](#).

2. Consult Fisher 657 and 667 instruction manuals (D100306X012, D100307X012, D100310X012, and D100311X012) for additional information on maximum pressure limitations.



Figure 2. Typical Top-Mounted Handwheels

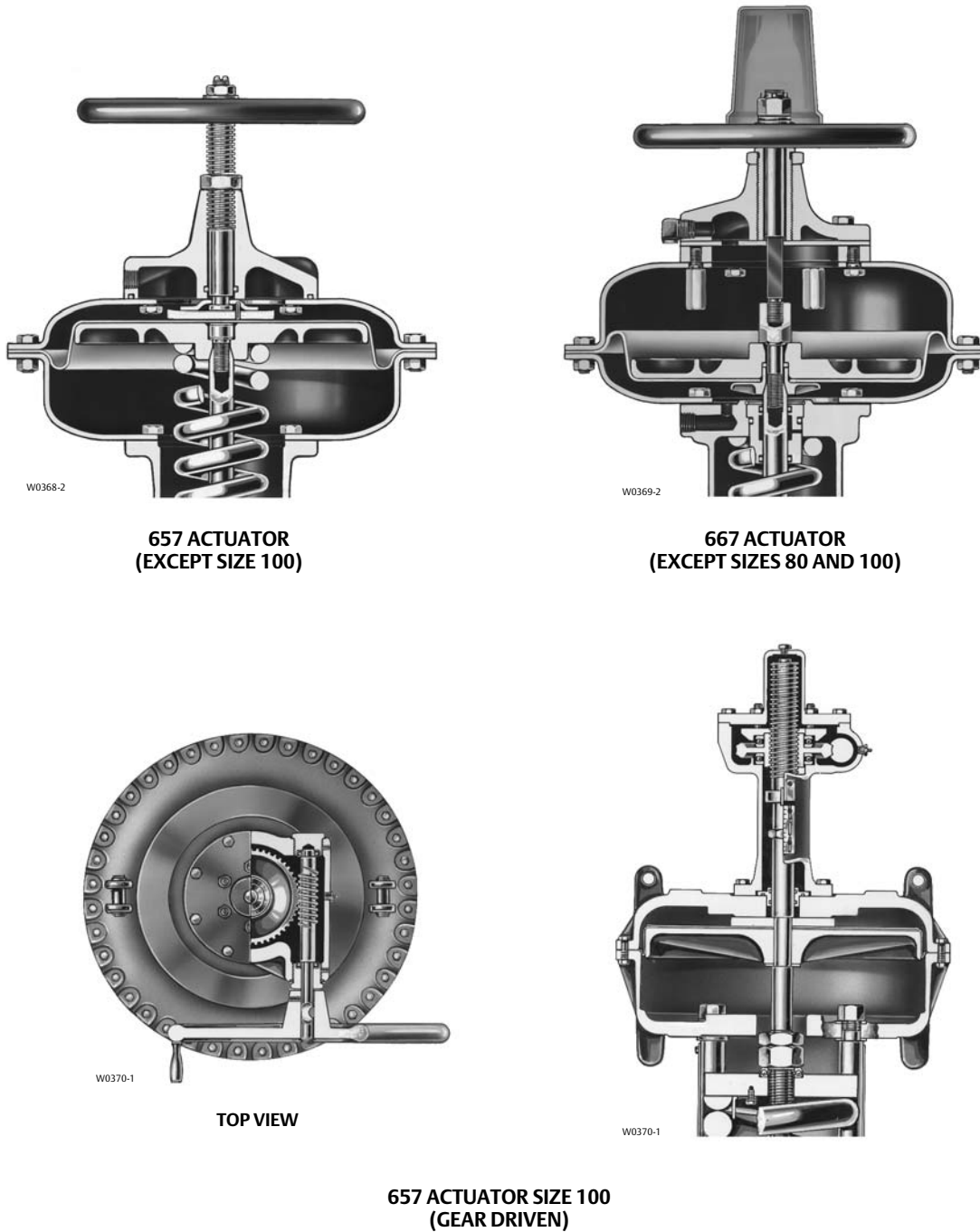

Figure 3. Typical Side-Mounted Handwheels for Fisher 657 and 667 Series Actuators

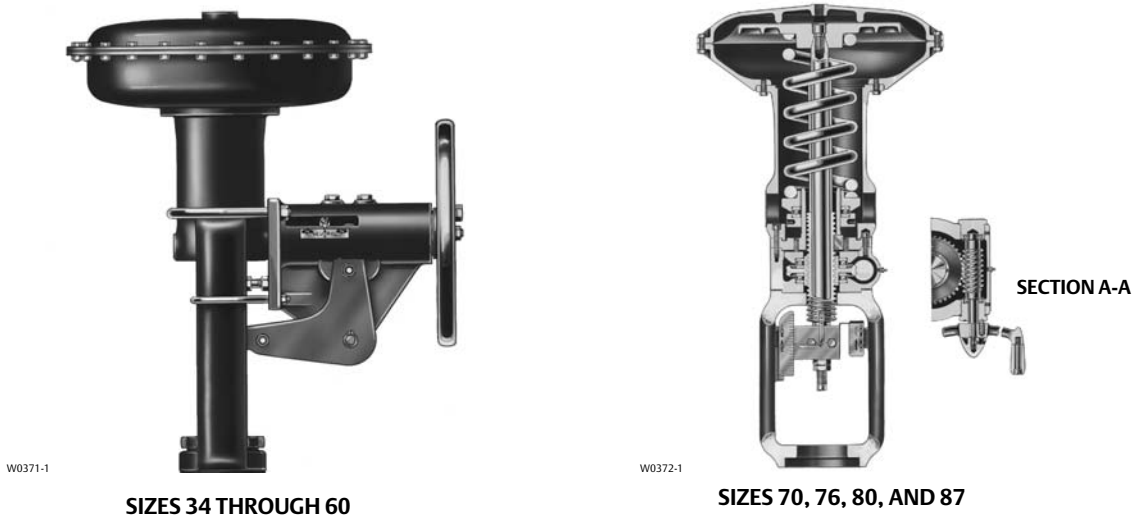

Figure 4. Adjustable Travel Stops

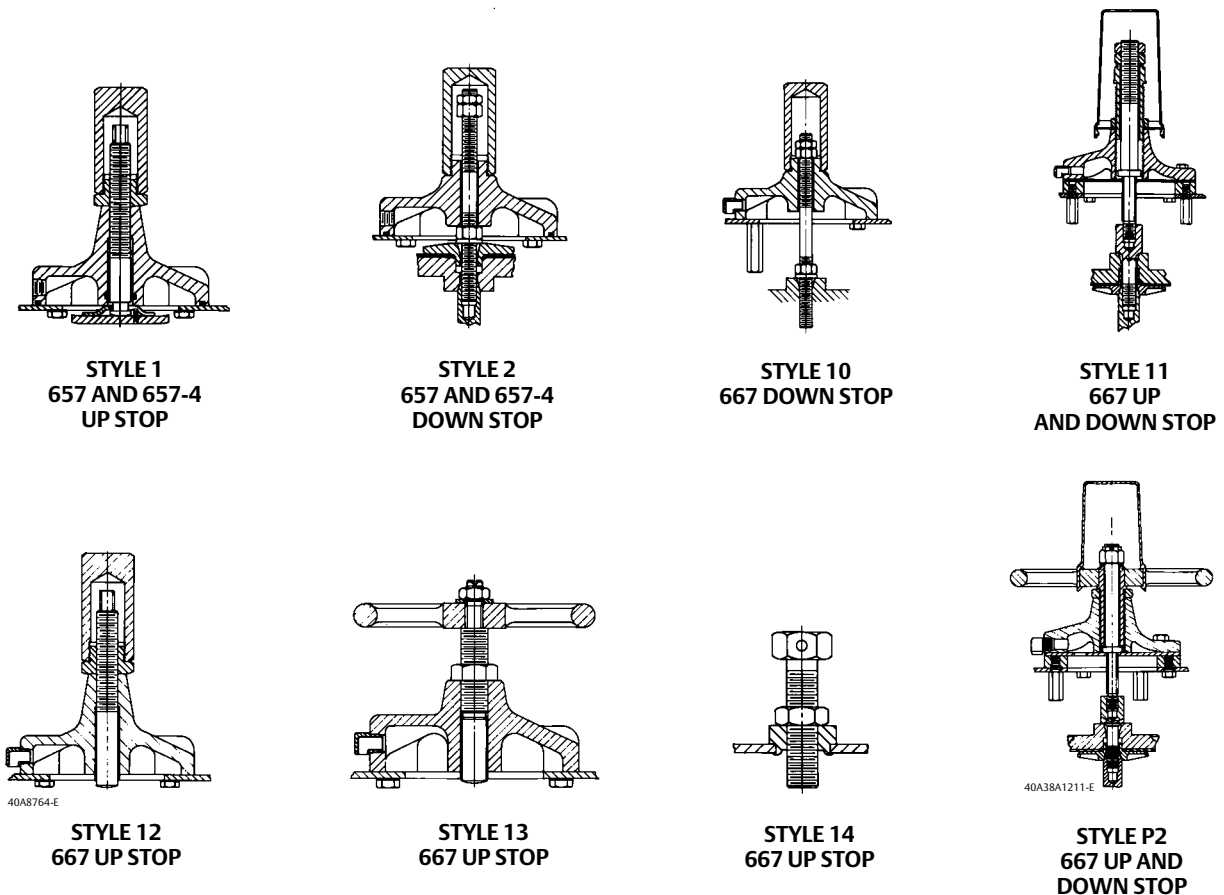

Table 5. Fisher 657 Handwheel Specifications

657 ACTUATOR SIZE	TOP-MOUNTED HANDWHEEL				SIDE-MOUNTED HANDWHEEL			
	Handwheel Diameter	Turns Per mm Travel	Rim Force <sup>(1)</sup>	Maximum Handwheel Output Force <sup>(3)</sup>	Handwheel Diameter	Turns Per mm Travel	Rim Force <sup>(1)</sup>	Maximum Handwheel Output Force <sup>(3)</sup>
	mm		N	N	mm		N	N
30	171	0.3	190	6670	---	---	---	---
34 and 40	222	0.3	210	10,010	304	0.2	230	10,010
45 and 50	222	0.3	420	15,080	355	0.3	360	15,080
46 and 60	222	0.3	490	22,690	355	0.3	540	22,690
70 and 87	355	0.3	590	29,360	432	0.8	160	29,360
80	355	0.3	770	37,770	432	0.4	240	37,770
100 <sup>(2)</sup>	406	6	270	160,000	---	---	---	---
	Inch	Turns Per Inch Travel	Lb	Lb	Inch	Turns Per Inch Travel	Lb	Lb
30	6.75	8	42	1500	---	---	---	---
34 and 40	8.75	8	48	2250	12	5.14	52	2250
45 and 50	8.75	8	95	3390	14	6.65	81	3390
46 and 60	8.75	8	110	5100	14	6.65	122	5100
70 and 87	14	8	132	6600	17	20	36	6600
80	14	8	173	8490	17	10	53	8490
100 <sup>(2)</sup>	16	144	60	36,000	---	---	---	---

1. Tangential handwheel force required to produce the handwheel output force shown. (Proportional to handwheel output force).  
2. Top-mounted with gear drive.  
3. Maximum force available to compress the actuator spring and close the valve.

Table 6. Fisher 667 Handwheel Specifications

667 ACTUATOR SIZE	TOP-MOUNTED HANDWHEEL				SIDE-MOUNTED HANDWHEEL				
	Handwheel Diameter	Turns Per mm Travel	Rim Force <sup>(1)</sup>	Maximum Handwheel Output Force <sup>(3)</sup>	667 ACTUATOR SIZE	Handwheel Diameter	Turns Per mm Travel	Rim Force <sup>(1)</sup>	Maximum Handwheel Output Force <sup>(3)</sup>
	mm		N	N		mm		N	N
30	171	0.3	200	6670	30	---	---	---	---
34 and 40	222	0.3	230	10,010	34 and 40	304	0.2	230	10,010
45 and 50	222	0.2	460	17,790	45 and 50	355	0.3	360	15,080
	355	0.2	430	26,690					
46, 60, and 76	222	0.2	460	17,790	46 and 60	355	0.3	540	22,690
	355	0.2	430	26,690					
70 and 87	355	0.2	520	26,690	70, 76, and 87	432	0.8	160	29,360
	762 mm Bar	0.2	410	44,480					
100 <sup>(2)</sup>	406	6	270	160,000	80	432	0.4	240	37,770
667 ACTUATOR SIZE	Inch	Turns Per Inch Travel	Lb	Lb	667 ACTUATOR SIZE	Inch	Turns Per Inch Travel	Lb	Lb
30	6.75	8	45	1500	30	---	---	---	---
34 and 40	8.75	8	51	2250	34 and 40	12	5.14	52	2250
45 and 50	8.75	6	103	4000	45 and 50	14	6.65	81	3390
	14	6	97	6000					
46, 60, and 76	8.75	6	103	4000	46 and 60	14	6.65	122	5100
	14	6	97	6000					
70 and 87	14	6	118	6000	70, 76, and 87	17	20	36	6600
	30 Inch Bar	6	92	10000					
100 <sup>(2)</sup>	16	144	60	36,000	80	17	10	53	8490

1. Tangential handwheel force required to produce the handwheel output force shown. (Proportional to handwheel output force).  
 2. Top-mounted with gear drive.  
 3. Maximum force available to compress actuator spring.

Table 7. Adjustable Travel Stop Styles <sup>(1)</sup>

Actuator Size	30	34	40	45	46	50	60 and 667 Size 76	70	87	80	100
657 Up Stop	1	1	1	1	1	1	1	1	1	NOTE 2	NOTE 2
657 Down Stop	2	2	2	2	2	2	2	2	2	---	---
667 Up Stop	12, 13 <sup>(3)</sup> , 14	12, 13 <sup>(3)</sup> , 14	12, 13 <sup>(3)</sup> , 14	12, 13 <sup>(3)</sup> , 14	12, 13 <sup>(3)</sup> , 14	12, 13 <sup>(3)</sup> , 14	12, 13 <sup>(3)</sup> , 14	12	12	13 <sup>(3)</sup>	---
667 Down Stop	10	10	10	10	10	10	10	10	10	---	NOTE 2
667 Up and Down Stop	---	11	11	11 <sup>(4)</sup> , P2 <sup>(5)</sup>	11 <sup>(4)</sup> , P2 <sup>(5)</sup>	11 <sup>(4)</sup> , P2 <sup>(5)</sup>	11 <sup>(4)</sup> , P2 <sup>(5)</sup>	---	---	---	---

1. See figure 4.  
 2. Top-mounted handwheel, see figure 2.  
 3. Adjustable handwheel up stop.  
 4. 38 mm (1.5 inch) maximum travel.  
 5. Adjustable handwheel up and down stop, 19 mm (0.75 inch) maximum travel.

Figure 5. Fisher 646 Electro-Pneumatic Transducer on 657 Actuator



W4917-1

Figure 7. Fisher 4200 Position Transmitter on 667 Actuator



W4273-1

Figure 6. Fisher 3582i Valve Positioner on 657 Actuator



W4930

Table 8. Dimensions

DIMENSION REFERENCE		ACTUATOR SIZE												
		30	34	40	45	46	47	50	60	70	76	80	87	100
		mm												
B	657,-4	0	25	25	38	38	38	38	38	38	---	---	38	---
	667,-4	38	38	38	38	38	38	38	38	38	38	---	38	---
C		289	333	333	406	473	536	406	473	536	473	635	536	729
D		54	54	71	71	71	71	90	90	90	90	127	127	127 <sup>(2)</sup>
E	657	440	498	548	659	656	---	722	722	840	---	1075	938	NOTE 3
	657-4	---	---	---	---	---	---	---	---	994	---	---	1089	---
	657MO <sup>(1)</sup>	440	498	548	659	656	---	722	722	976	---	1183	1057	NOTE 4
	657-4 MO	---	---	---	---	---	---	---	---	1124	---	---	1204	---
	667	478	573	594	768	748	---	784	784	933	881	1257	1003	1857
	667-4	---	---	---	---	---	---	---	---	1070	---	---	1143	---
H <sub>c</sub>	657	121	164	164	202	202	---	202	202	313	---	227	313	---
	667	119	121	137	159	159	---	159	159	286	159	---	286	---
H <sub>s</sub>		---	284	286	375	375	---	378	378	292	222	303	292	401
J <sub>c</sub>		171	222	222	222	222	356	222	222	356	356	356	356	---
J <sub>s</sub>		---	305	305	356	356	---	356	356	432	432	432	432	406
K	657,-4	213	222	272	291	291	395	354	354	406	---	435	780	451
	667,-4	194	224	244	310	310	---	325	325	375	375	432	419	451
M	657,-4	---	226	248	306	306	---	370	370	446	---	503	527	NOTE 5
	667,-4	---	214	248	362	362	---	378	378	446	446	503	527	2105
N	657	---	---	---	---	---	---	---	---	---	---	254	---	---
	657MO	---	---	---	---	---	---	---	---	219	---	384	219	---
	657-4MO	---	---	---	---	---	---	---	---	219	---	---	219	---
	667	---	---	---	---	---	---	---	---	---	---	254	---	---
H <sub>c</sub>	667MO	---	---	---	---	---	---	---	---	219	219	384	219	---
	667-4MO	---	---	---	---	---	---	---	---	219	---	---	219	---
Inches														
B	657,-4	0.00	1.00	1.00	1.50	1.50	1.50	1.50	1.50	1.50	---	---	1.50	---
	667,-4	1.50	1.50	1.50	1.50	1.50	1.50	1.50	1.50	1.50	1.50	---	1.50	---
C		11.38	13.12	13.12	16.00	18.62	21.12	16.00	18.62	21.12	18.62	25.00	21.12	28.69
D		2.125	2.125	2.8125	2.8125	2.8125	2.8125	3.5625	3.5625	3.5625	3.5625	5	5	5 <sup>(2)</sup>
E	657	17.31	19.62	21.56	25.94	25.81	---	28.44	28.44	33.06	---	42.31	36.94	NOTE 3
	657-4	---	---	---	---	---	---	---	---	39.12	---	---	42.88	---
	657MO	17.31	19.62	21.56	25.94	25.81	---	28.44	28.44	38.44	---	46.56	41.62	NOTE 4
	657-4 MO	---	---	---	---	---	---	---	---	44.25	---	---	47.38	---
	667	18.81	22.56	23.38	30.25	29.44	---	30.88	30.88	36.75	34.70	49.50	39.50	73.12
	667-4	---	---	---	---	---	---	---	---	42.12	---	---	45.00	---
H <sub>c</sub>	657	4.75	6.44	6.44	7.94	7.94	---	7.94	7.94	12.31	---	8.94	12.31	---
	667	4.69	4.75	5.38	6.25	6.25	---	6.25	6.25	11.25	6.25	---	11.25	---
H <sub>s</sub>		---	11.19	11.25	14.75	14.75	---	14.88	14.88	11.50	11.50	11.94	11.50	15.78
J <sub>c</sub>		6.75	8.75	8.75	8.75	8.75	14.00	8.75	8.75	14.00	8.75	14.00	14.00	---
J <sub>s</sub>		---	12.00	12.00	14.00	14.00	---	14.00	14.00	17.00	17.00	17.00	17.00	16.00
K	657,-4	8.38	8.75	10.69	11.44	11.44	15.56	13.94	13.94	16.00	---	17.12	18.88	17.75
	667,-4	7.62	8.83	9.62	12.19	12.19	---	12.81	12.81	14.75	14.75	17.00	16.50	17.75
M	657,-4	---	8.88	9.75	12.06	12.06	---	14.56	14.56	17.56	---	19.81	20.75	NOTE 5
	667,-4	---	8.44	9.75	14.25	14.25	---	14.88	14.88	17.56	17.56	19.81	20.75	82.88
N	657	---	---	---	---	---	---	---	---	---	---	10.00	---	---
	657MO	---	---	---	---	---	---	---	---	8.62	---	15.12	8.62	---
	657-4MO	---	---	---	---	---	---	---	---	8.62	---	---	8.62	---
	667	---	---	---	---	---	---	---	---	---	---	10.00	---	---
H <sub>c</sub>	667MO	---	---	---	---	---	---	---	---	8.62	8.62	15.12	8.62	---
	667-4MO	---	---	---	---	---	---	---	---	8.62	---	---	8.62	---

1. MO = Manual operator.  
 2. Also available with 7 inch boss.  
 3. With group 1 springs, E=1959 mm (77.12 inch). With group 2 springs, E=1497 mm (58.94 inch).  
 4. With group 1 springs, E=2345 mm (92.31 inch). With group 2 springs, E=1883 mm (74.12 inch).  
 5. With group 1 springs, M=2103 mm (82.81 inch). With group 2 springs, M=1654 mm (65.12 inch).

Figure 8. Dimensions (also see table 8)

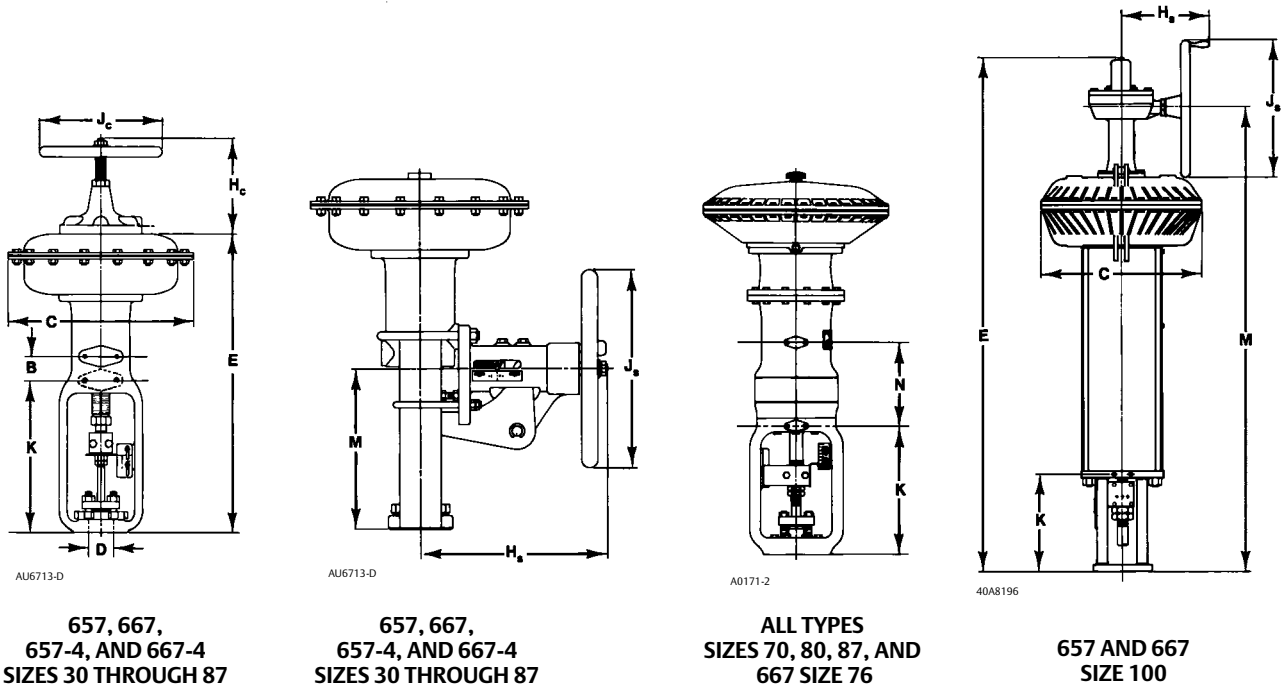

## Ordering Information

When ordering, specify:

### Application

1. On-off or throttling service
2. Input signal range
3. Maximum supply pressure
4. Valve body type and size with which the actuator will be used
5. Valve plug travel
6. Actuator thrust required with actuator stem both fully retracted and fully extended
7. Stroking time requirements, if critical
8. Seismic requirements, if critical

9. Ambient temperature range

### Actuator and Positioner

Be sure to specify: actuator type number; whether a positioner is required; whether a top-mounted handwheel is required; and whether an adjustable up or down travel stop is required. Refer to the Specifications section. Review the information under each specification and in the referenced tables and figures. Specify the desired choice wherever there is a selection to be made.

### Valve Body and Accessories

Refer to the separate valve body bulletin and bulletins covering accessories for ordering information.

Neither Emerson, Emerson Process Management, nor any of their affiliated entities assumes responsibility for the selection, use or maintenance of any product. Responsibility for proper selection, use, and maintenance of any product remains solely with the purchaser and end user.

Fisher and easy-e are marks owned by one of the companies in the Emerson Process Management business unit of Emerson Electric Co. Emerson Process Management, Emerson, and the Emerson logo are trademarks and service marks of Emerson Electric Co. All other marks are the property of their respective owners.

The contents of this publication are presented for informational purposes only, and while every effort has been made to ensure their accuracy, they are not to be construed as warranties or guarantees, express or implied, regarding the products or services described herein or their use or applicability. All sales are governed by our terms and conditions, which are available upon request. We reserve the right to modify or improve the designs or specifications of such products at any time without notice.

Emerson Process Management  
Marshalltown, Iowa 50158 USA  
Sorocaba, 18087 Brazil  
Cernay, 68700 France  
Dubai, United Arab Emirates  
Singapore 128461 Singapore

[www.Fisher.com](http://www.Fisher.com)