

# Errata Sheet for Fisher® D3 Control Valve with easy-Drive™ Electric Actuator, Instruction Manual, dated June 2013

This errata sheet provides information for the Fisher easy-Drive electric actuator. Use this in conjunction with information provided in the (Fisher D3 Control Valve with easy-Drive Electric Actuator) instruction manual (D103460X012) dated June 2013.

## Important technical notice for easy-Drive electric actuator

When using the easy-Drive electric actuator with a 4-20mA control signal, the unit should always have 12/24VDC power present on the power input terminals prior to applying the 4-20mA signal, unless an external 250Ω resistor is in place across the analog control input terminals. Failure to do so could result in damage to the analog input circuitry. The following installation and configuration procedure should be observed to ensure reliable operation.

1. Configure the local analog input control signal to 1-5V. This can be accomplished by the configuration software or by setting Modbus register 40043 to 0.
2. Install a 1/4 or 1/2 watt, 250Ω resistor between terminals 3 and 4 (Analog+ and Analog -) when landing the 4-20mA control wiring on those terminals. A 220Ω or 270Ω resistor may be used as well if a 250Ω resistor is not readily available.

Figure 1. Wiring Diagram

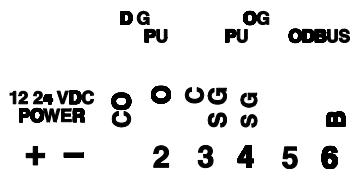

3. Apply a 100% signal to the actuator with the resistor in place and calibrate the analog input to 100% through the configuration software or by sending a value of 1 to register 40005.
4. Apply a 0% signal to the actuator with the resistor in place and calibrate the analog input to 0% through the configuration software or by sending a value of 1 to register 40004.

The result of not following these installation instructions could result in permanent damage to the analog input circuitry. This damage can result in the inability of the controller to see the control signal, resulting in the actuator moving the valve plug to the loss of signal position.

This configuration works by providing the 4-20mA signal a path to follow through the resistor whether primary power to the actuator is on or off, which prevents the voltage on the analog input terminals from rising high enough to damage the circuitry.

---

**Note**

Do not configure the actuator to 4-20 mA with the external resistor in place, as improper operation will result.

---

**▲ WARNING**

**Use only genuine Fisher replacement parts. Components that are not supplied by Emerson Process Management should not, under any circumstances, be used in any Fisher valve, because they may void your warranty, might adversely affect the performance of the valve, and could cause personal injury and property damage.**

---

**Neither Emerson, Emerson Process Management, nor any of their affiliated entities assumes responsibility for the selection, use or maintenance of any product. Responsibility for proper selection, use, and maintenance of any product remains solely with the purchaser and end user.**

Fisher and easy-Drive are marks owned by one of the companies in the Emerson Process Management business unit of Emerson Electric Co. Emerson Process Management, Emerson, and the Emerson logo are trademarks and service marks of Emerson Electric Co. All other marks are the property of their respective owners.

The contents of this publication are presented for informational purposes only, and while every effort has been made to ensure their accuracy, they are not to be construed as warranties or guarantees, express or implied, regarding the products or services described herein or their use or applicability. All sales are governed by our terms and conditions, which are available upon request. We reserve the right to modify or improve the designs or specifications of such products at any time without notice.

**Emerson Process Management**

Marshalltown, Iowa 50158 USA

Sorocaba, 18087 Brazil

Chatham, Kent ME4 4QZ UK

Dubai, United Arab Emirates

Singapore 128461 Singapore

[www.Fisher.com](http://www.Fisher.com)

# Fisher® D3 Control Valve with easy-Drive™ Electric Actuator

## Contents

Introduction .....	1
Scope of Manual .....	1
Description .....	3
Specifications .....	3
Educational Services .....	3
Installation .....	3
Special Instructions for “Safe Use” and Installations in Hazardous Locations .....	4
Startup Overview .....	5
Important Technical Notice for easy-Drive Electric Actuator .....	8
Default Input Signals .....	9
Configuration .....	9
Input Configuration .....	9
Changing the Inputs from Default Settings ...	9
Modbus Setup .....	9
Calibration Instructions .....	11
Setting the Valve Flow Adjuster .....	15
Troubleshooting .....	14
Maintenance .....	16
Valve Plug and Seat Ring Maintenance .....	18
Packing Maintenance .....	20
Parts Ordering .....	22
Parts Kits .....	22
Parts List .....	22
Appendix A - Modbus .....	25

Figure 1. Fisher D3 Control Valve with easy-Drive Electric Actuator



W9795-4

## Introduction

### Scope of Manual

This instruction manual provides installation, maintenance, and parts information for the Fisher D3 control valve with easy-Drive electric actuator.

Do not install, operate, or maintain a D3 valve with easy-Drive electric actuator without being fully trained and qualified in valve, actuator, and accessory installation, operation, and maintenance. **To avoid personal injury or property damage, it is important to carefully read, understand, and follow all the contents of this manual, including all safety cautions and warnings.** If you have any questions about these instructions, contact your Emerson Process Management sales office before proceeding.



Table 1. Specifications

**Valve Body Sizes, End Connection Styles, and Port Diameters<sup>(1)</sup>**

VALVE SIZE, NPS	PORT DIAMETER, (INCHES)	THREADED	RAISED FACE (RF) FLANGED
		CL900	CL600
1	0.375, 0.75, 1	X	X
2	0.375, 0.75, 1	X	X

X = Available construction.

**Maximum Inlet Pressures and Temperatures<sup>(1)</sup>**

VALVE BODY SIZE	MAXIMUM INLET PRESSURE	TEMPERATURE RANGE
	bar (psig)	°C (°F)
NPS 1 NPT CL900	155 (2250)	-46 to 93 (-50 to 200)
	150 (2185)	93 to 149 (200 to 300)
NPS 2 NPT CL900	155 (2250)	-46 to 93 (-50 to 200)
	150 (2185)	93 to 149 (200 to 300)
NPS 1 RF CL600	103 (1500)	-46 to 93 (-50 to 200)
	100 (1455)	93 to 149 (200 to 300)
NPS 2 RF CL600	103 (1500)	-46 to 93 (-50 to 200)
	100 (1455)	93 to 149 (200 to 300)

**Maximum Shutoff Pressure Drops<sup>(1)</sup>**

Port Size, mm (inch)	MAXIMUM ΔP BAR (PSI) PER PORT SIZE		
	9.5 (0.375)	19.1 (0.75)	25.4 (1.00)
Flow Up	155 (2250)	105 (1518)	75 (1089)
Flow Down	155 (2250)	155 (2250)	130 (1889)

**Shutoff Classification per ANSI/FCI 70-2 and IEC 60534-4**

Class IV

**Flow Characteristic / Valve Plug Style**

Equal percentage / Micro-Form Valve Plug

**Maximum Travel**

15 mm (0.6 inch)

**Material Temperature Capabilities<sup>(1)</sup>**

Valve Body Assembly: -46 to 149°C (-50 to 300°F)

Electric Actuator Assembly: -20 to 70°C (-4 to 158°F), &lt; 90% non-condensing humidity

**Flow Direction**

Flow up (standard), Flow down (optional)

**Available Actuator Configurations**On/off (snap acting)  
Positioning (flow or pressure control)**Power Requirements**

12 or 24VDC, minimum 4 amp power supply required (fuse to 5 amps)

**Maximum Current Draw**

4 amps

**Idle Current Draw**

38 mA

**Conduit Connections**

Two 3/4 NPT connections

**Stroke Length**

FloPro controlled between 10mm (0.4 inch) and 15mm (0.6 inch)

**Nominal Stroke Speed<sup>(2)</sup>**3.9 mm/s (0.15 inch/s) at 24 VDC  
2.2 mm/s (0.09 inch/s) at 12 VDC**Hazardous Area Approvals**

CSA (C/US): Explosion-Proof Class I, Division 1, Groups C and D, T6, Ex d IIA T6, Class I, Zone 1, AEx d IIA T6

ATEX Flameproof - Gas:

Ex II 2 G, Ex d IIA T6

IECEx Flameproof - Gas: Ex d IIA T6

**Enclosure Rating**

Type 4X and IP66

**Duty Cycle**

50% maximum

**Enclosure Material**

Cast aluminum alloy with powder coat paint

**Approximate Weight:**

18 - 27 kg (39 - 60 lbs), depending upon construction

1. The pressure or temperature limits in the referenced tables and any applicable ASME code limitations should not be exceeded.  
2. 10% variation can be expected, based on temperature and pressure of application.

## Description

The Fisher D3 with easy-Drive electric actuator technology (figure 1) is a globe valve with electric actuator specifically designed for upstream, low power applications. The easy-Drive operates with 12 or 24VDC in either on/off or Positioning configurations.

The on/off configuration has 2 different states; opened or closed, which are ideal for dump or snap acting applications. The Positioning configuration extends the functionality to intermediate positions for flow and pressure control applications.

## Specifications

Table 1 lists specifications for the D3 control valve. Some of the specifications for a given control valve as it originally comes from the factory are stamped on a nameplate located on the lower actuator housing.

## Educational Services

For information on available courses for the Fisher D3 control valve with easy-Drive electric actuator, as well as a variety of other products, contact:

Emerson Process Management  
Educational Services, Registration  
P.O. Box 190; 301 S. 1<sup>st</sup> Ave.  
Marshalltown, IA 50158-2823  
Phone: 800-338-8158 or  
Phone: 641-754-3771  
FAX: 641-754-3431  
e-mail: education@emerson.com

## Installation

### WARNING

Always wear protective gloves, clothing, and eyewear when performing any installation operations to avoid personal injury.

To avoid personal injury or property damage caused by bursting of pressure-retaining parts or by uncontrolled process fluid, be certain the service conditions do not exceed the limits shown on the valve nameplate and in table 1. Use pressure-relieving devices required by government or accepted industry codes and good engineering practices.

Check with your process or safety engineer for any additional measures that must be taken to protect against process media.

If installing into an existing application, also refer to the WARNING at the beginning of the Maintenance section in this instruction manual.

---

### WARNING

For explosion-proof applications, ensure the actuator cover is properly bolted before applying power to the actuator. Personal injury or property damage may result from fire or explosion if power is applied to the actuator with the cover removed in a hazardous area.

For explosion-proof applications, install rigid metal conduit and a conduit seal no more than 457 mm (18 inches) from the actuator. Personal injury or property damage may result from explosion if the seal is not installed.

Select wiring and/or cable glands that are rated for the environment of use (such as hazardous area, ingress protection, and temperature). Failure to use properly rated wiring and/or cable glands can result in personal injury or property damage from fire or explosion.

Wiring connections must be in accordance with local, regional, and national codes for any given hazardous area approval. Failure to follow the local, regional, and national codes could result in personal injury or property damage from fire or explosion.

## CAUTION

When ordered, the valve configuration and construction materials were selected to meet particular pressure, temperature, pressure drop, and controlled fluid conditions. Responsibility for the safety of process media and compatibility of valve materials with process media rests solely with the purchaser and end-user. Since some body/trim material combinations are limited in their pressure drop and temperature ranges, do not apply any other conditions to the valve without first contacting your Emerson Process Management sales office.

To avoid product damage, inspect the valve before installation for any damage or any foreign material that may have collected in the valve body. Also remove any pipe scale, welding slag, or other foreign material from the pipeline.

1. Before installing the control valve assembly, inspect it for any damage and for any foreign material that may have collected in the valve body.
2. Clean out all pipelines to remove scale, welding slag, and other foreign materials.
3. The control valve assembly may be installed in any orientation, but normally the actuator is vertical above the valve. Install the valve so the flow direction arrow on the side of the valve indicates the direction of the process flow.
4. Install the valve following local and national piping codes when they apply to the application. For screwed connections, treat the external pipe threads with a good grade pipe compound. For flanged connections, use suitable gaskets between valve and pipeline flanges.
5. If continuous operation is required during inspection or maintenance, install a three-valve bypass around the control valve assembly.

## Special Instructions for “Safe Use” and Installations in Hazardous Locations

### ATEX/IECEx

## ▲ WARNING

To avoid static discharge from the enclosure, do not rub or clean the enclosure with solvents. To do so could result in an explosion. Clean with a mild detergent and water only.

The enclosure is non-conducting and may generate an ignition-capable level of electrostatic charges under certain extreme conditions. The user should ensure that the equipment is not installed in a location where it may be subjected to external conditions (such as high-pressure steam) which might cause a build-up of electrostatic charges on non-conducting surfaces. Additionally, cleaning of the equipment shall only be done with a damp cloth.

To avoid damage to the enclosure, when screws are fully tightened into blind holes in enclosure walls, with no washer fitted, at least one full thread shall remain free at the base of the hole.

## Startup Overview

Figure 2. Flowchart

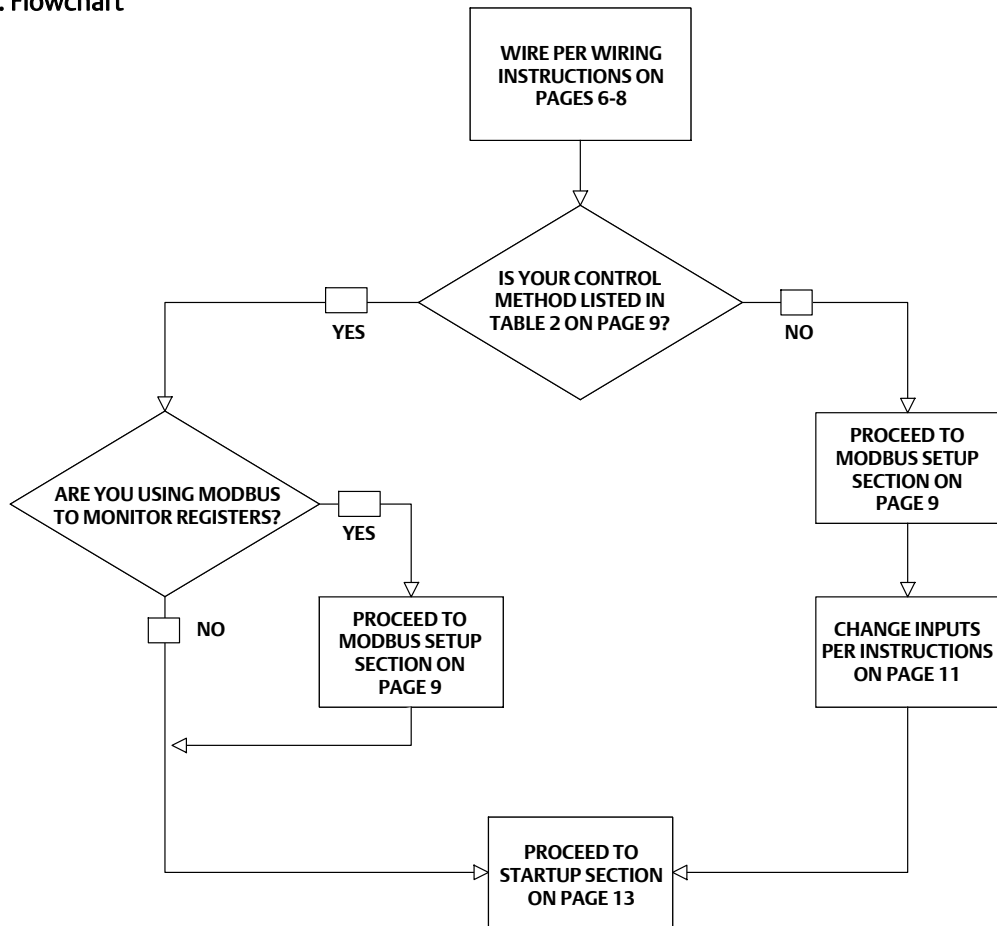
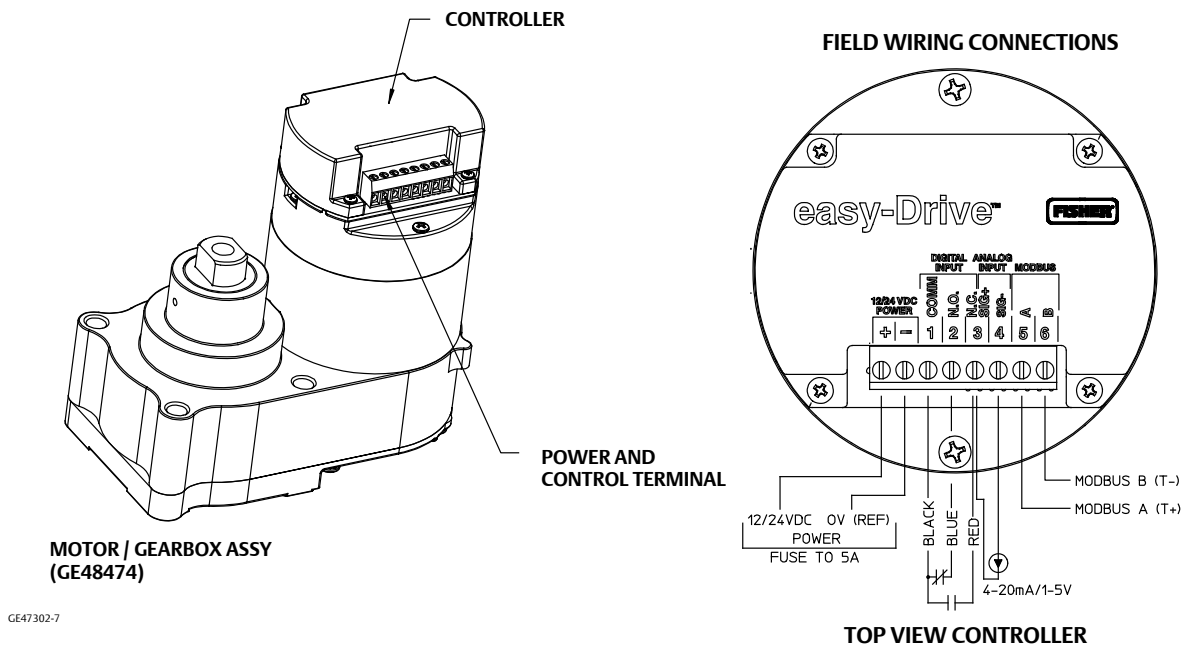

Figure 3. Fisher D3 Valve with easy-Drive Actuator Wiring Diagram



## Power Requirements

Ensure a stable DC power source is available, maintaining less than 5% ripple and sufficiently surge protected for the application. A 4 amp (minimum) power supply is required. Use of a 36 volt transient voltage suppressor is highly recommended.

## Wiring Instructions

1. Observe local wiring requirements for hazardous location usage.
2. Conduit seals within 450 mm (18 inches) of the enclosure port are required for explosion-proof installation.
3. 22AWG (0.33mm<sup>2</sup>) to 12AWG (3.31mm<sup>2</sup>) wire size required.
4. Fuse system to 5A.
5. Connect enclosure and analog signal shields.
6. Ensure power is turned off before connecting the wires.

### Power

1. Connect 12 or 24 VDC reference to: –
2. Connect 12 or 24 VDC positive to: +
3. Be sure to tighten terminals sufficiently to ensure solid mechanical connection.



Figure 4. Wiring - Analog Input

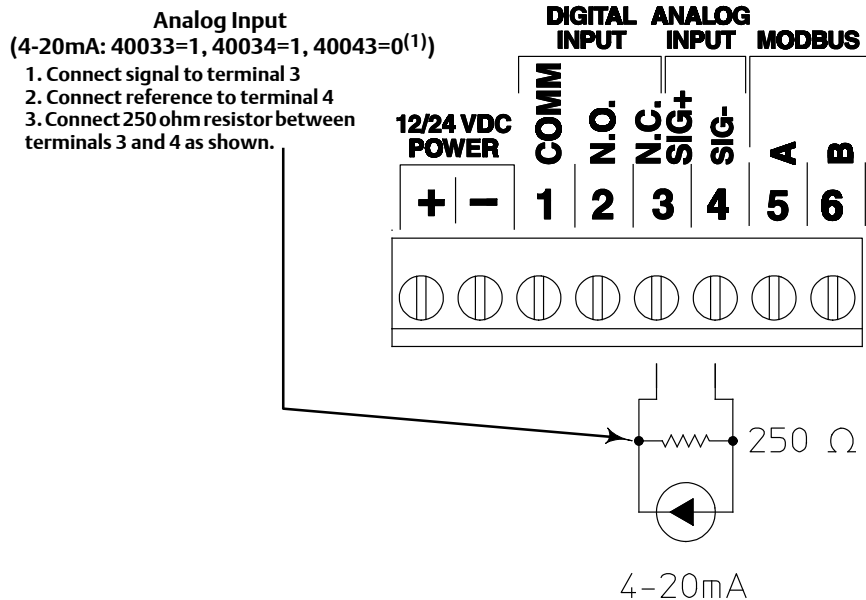

NOTE:  
1. 40043=0 SETS ANALOG INPUT TO 1-5V AND ASSUMES USE OF RECOMMENDED EXTERNAL 250 OHM RESISTOR. IF NO EXTERNAL RESISTOR IS USED, SET 40043=1.

Figure 5. Wiring - L2e

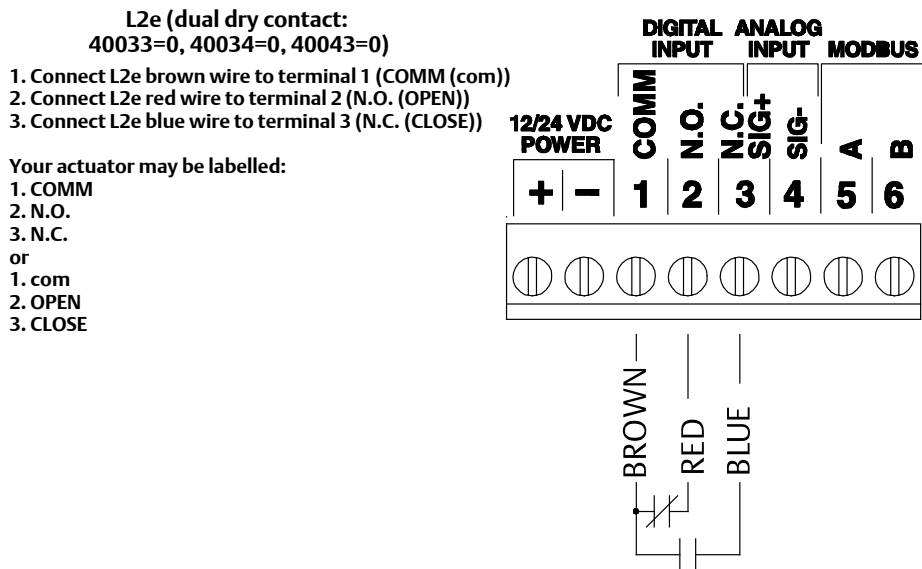

Figure 6. Wiring - Single Dry Contact

Dry Contact (single dry contact:  
40033=0, 40034=0, 40043=1)

1. Connect one side of contact switch to terminal 1 (COMM)
2. Connect other side of contact switch to terminal 2 (N.O.)

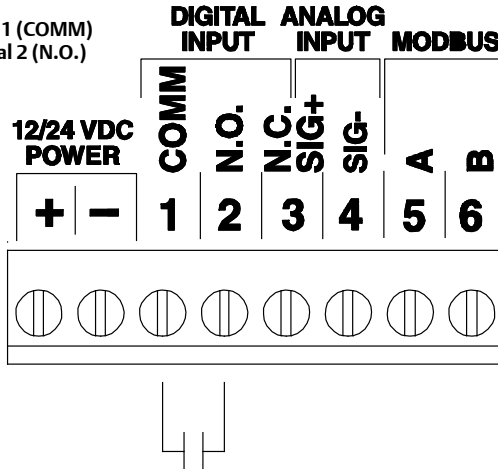

Figure 7. Wiring - Modbus Input

Modbus Input: 40033=1

1. Connect Channel A (T+) to terminal 5
2. Connect Channel B (T-) to terminal 6

Modbus Defaults

Address 1  
9600 Baud  
Even parity  
1 Stop Bit

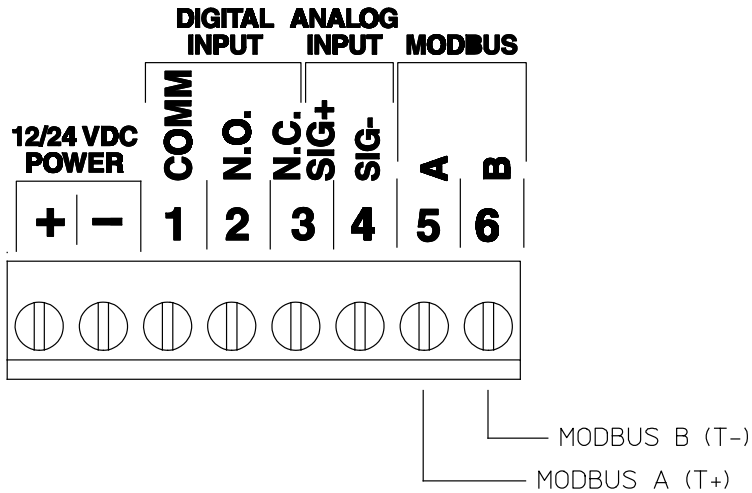

## Important Technical Notice for easy-Drive Electric Actuator

When using the easy-Drive electric actuator with a 4-20mA control signal, the unit should always have 12/24VDC power present on the power input terminals prior to applying the 4-20mA signal, unless an external 250 ohm resistor is installed per figure 4. Failure to do so could result in damage to the analog input circuitry.

It is strongly recommended to place an external 250 ohm resistor between terminals 3 and 4 when using a 4-20mA signal to control the actuator. When the actuator is configured to 1-5V input with an external 250 ohm resistor in place, a 4-20mA signal may be safely used without danger to input circuitry.

This order of operation must always be maintained when powering the unit on if no external 250 ohm resistor is used:

1. 12/24VDC power on
2. 4-20mA control signal engaged

This order of operation must always be maintained when powering the unit off:

1. 4-20mA control signal disengaged
2. 12/24VDC power off

The result of not following this order of operation could result in permanent damage to the analog input circuitry. This damage can result in the inability of the controller to see the control signal, resulting in the actuator moving the valve plug to the loss of signal position.

## Default Input Signals

The D3 with easy-Drive comes from the factory calibrated and ready for use with the following default input signals shown in table 2.

**Table 2. D3 easy-Drive Default Input Signals**

CONFIGURATION	ON/OFF	POSITIONING
Input Signal	L2e (dual dry contact)	4-20 mA

If the input signal of the application matches table 2, proceed to the Wiring Instructions section. If the input signal of the application does not match table 2, proceed to the Configuration section.

## Configuration

### Input Configuration

There are 2 functional configurations available for the easy-Drive electric actuator: On/Off and Positioning. It is not possible to change an actuator from On/Off to Positioning after it has been delivered from the factory. Version 4.21 and higher firmware will allow a positioning unit to be changed to on/off.

All available input signals are shown in table 3.

**Table 3. All Available Input Signals**

CONFIGURATION	ON/OFF			POSITIONING		
	Control Source	Modbus	Local	Modbus	Local	
Input Signal	Modbus	L2e Dual Dry Contact (default)	Single Dry Contact	Modbus	4-20 mA (default)	1-5 V

If you are using the default inputs signals, and the valve has not been disassembled or adjusted in any way, there is no need to recalibrate the assembly. You can proceed directly to Startup (page 12).

### Changing the Inputs from Default Settings

All configuration within the valve is done by setting values in Modbus registers. This can be done using any Modbus master (flow computer, PLC, PC). Configuration software, providing a visual interface to the registers, is available through your Emerson local business partner or the Fisher website.

## Modbus setup

Use the instructions in the instruction manual for the Modbus master to initiate the connection. The D3 with easy-Drive electric actuator Modbus factory defaults are Address 1, 9600 baud, even parity, 1 stop bit.

When a connection has been achieved, the actuator may be configured to accept the input signal over the Modbus link (ignoring the physical inputs) and the Modbus settings may be changed to accommodate the network to which it is attached. Other changes to functionality are possible, such as:

- Low level cutoff: 40037 (default is 5%)
- Position upon loss of signal: 40035 (default is 0%)

See Appendix A for a full map of Modbus registers and their functions.

**Figure 8. Fisher easy-Drive Configuration Software**

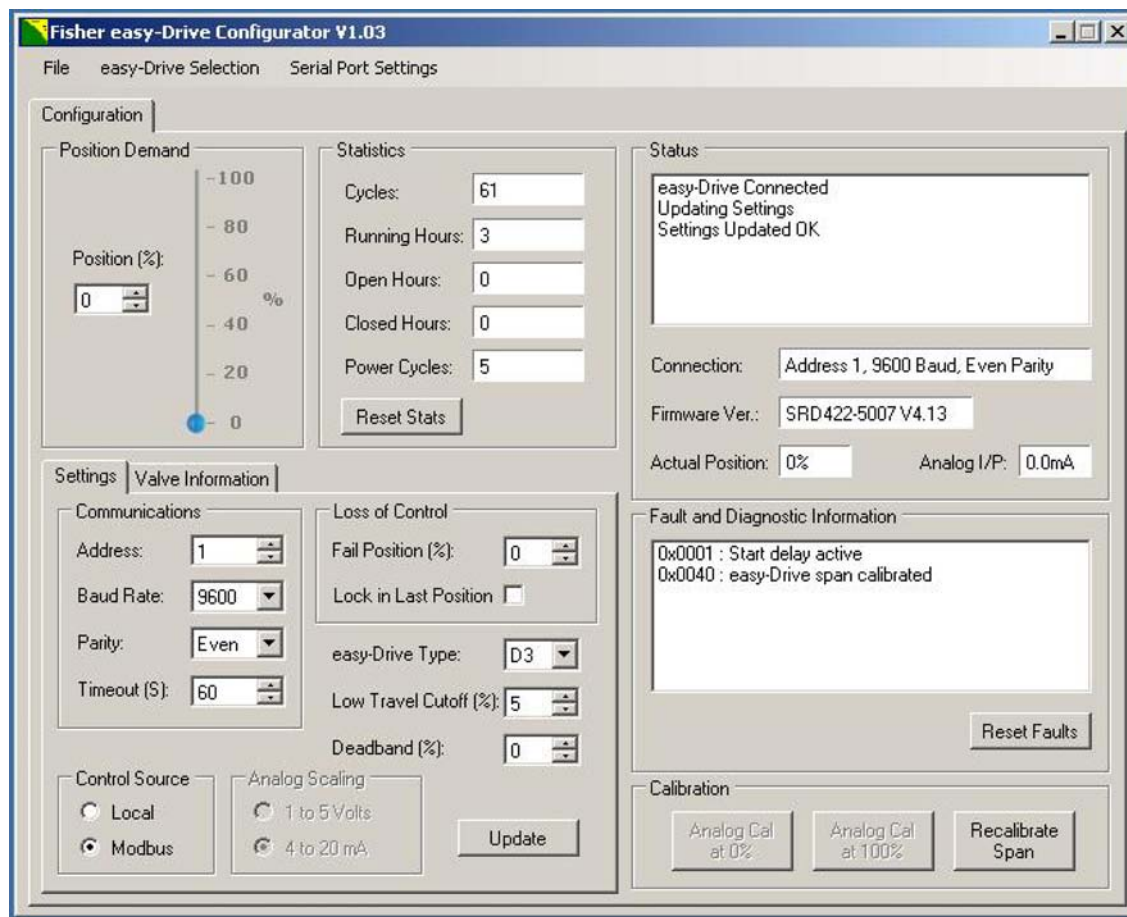

## Connecting using the Fisher easy-Drive configuration software

The Fisher easy-Drive configuration software allows configuration and diagnosing of the Fisher easy-Drive electric actuator with a graphical interface. Connect a PC to the actuator using a USB or serial device to Modbus RTU converter using the wiring instructions above. The USB or serial device will be visible in the drop menu under Serial Port Settings. Baud rate and parity should be set to the Modbus settings of the actuator. Default actuator settings are 9600 baud and Even parity.

Use the Fisher easy-Drive configuration software (figure 8) to make the desired changes, or register values may be changed to allow different functionality. Modbus register 40034 dictates whether the unit will respond to a physical

signal or to the value in Modbus register 40001. A value of 0 in register 40034 will result in the actuator responding to the value in 40001 and a value of 1 will result in the actuator responding to physical control signals.

---

**Note**

If an actuator is on/off, a Modbus command of 0-49 in register 40001 will cause the valve to close fully, while a value of 50-100 will cause the valve to open fully.

---

## Local to Modbus Control

### Modbus

- Set register 40034 (Control Source)
  - 1 = Local Control
  - 0 = Modbus control

### Configuration Software

- Use radio button to select Local Control or Modbus Control.

## 4-20mA to 1-5V Control

### Modbus

- Set register 40043 (Analog I/P mode)
  - 0 = 1-5V
  - 1 = 4-20mA

### Configuration Software

- Use radio button to select 4-20mA or 1-5V local analog control when Control Source is set to Local.

## L2e (Dual dry contact) to Single Dry Contact Control

### Modbus

- Set register 40043 (Analog I/P mode)
  - 0 = L2e (Dual dry contact)
  - 1 = Single dry contact

### Configuration Software

- Use radio button to select L2e or Single pole local digital control when Control Source is set to Local.

## Calibration Instructions

** WARNING**

To avoid personal injury or property damage, be aware that the valve will open fully and then close fully during the calibration cycle.

---

It is not necessary to calibrate your easy-Drive electric actuator prior to use from a factory shipment.

If any of the following are true, recalibration will be required (see next section)

- A change in the Flo-Pro setting
- The actuator has been re-mounted on a different valve since shipment
- Disassembly of the valve for trim or packing changes
- A new version of firmware has been loaded on the controller

The following scenarios do not require recalibrations

- New unit from the box
- Power dips or interruptions
- Changing of control method (i.e. from 4-20mA to Modbus control)
- Extended periods of storage

### Calibration with the use of Modbus

1. After the unit has been properly wired and fused per instructions in the Wiring section of this instruction manual, turn power to the unit on.
2. Calibrate using Modbus:
  - a. Send position command of 0% to actuator to prevent unexpected motion. Valve will move to commanded position following the calibration procedure.
  - b. Send a value of 1 to register 40003. Valve plug will move to fully open position and then to fully closed. The valve plug will then return to the commanded position.

If a Modbus connection is not available, and recalibration is desired, use the appropriate calibration method as determined by the control method of your valve.

### Calibration without the use of Modbus

1. Turn power to the actuator off.
2. Wait for 10 seconds to ensure all circuits have discharged.
3. Return power to the actuator and use the appropriate calibration method for your control signal. Calibration sequence must be done within 15 seconds of power being switched on.
4. For On/Off operation using L2e dual-input dry contact:
  - a. Close the contact to create a short between pins 1 and 2 – valve plug will not move at this time.
  - b. Close the contact to create a short between pins 1 and 3 – valve plug will move to the upper, open position and then to the lower, closed position.
5. For On/Off operation using single dry contact:
  - a. Close the contact to create a short between pins 1 and 2 – valve plug will not move at this time.
  - b. Open the contact to create an open circuit between pins 1 and 2 – valve plug will move to the upper, open position and then to the lower, closed position.

6. For positioning operation using 4-20mA:
  - a. Apply a 20mA signal between pins 3 and 4 – valve plug will not move at this time.
  - b. Apply a 4mA signal between pins 3 and 4 – valve plug will move to the upper stop, immediately followed by moving to the lower, closed position.
  - c. If calibration of the analog input is desired to improve positional accuracy, an optional operation is listed in the next section titled Analog Input Calibration.
7. For positioning operation using 1-5V:
  - a. Apply a 5V signal between pins 3 and 4 – valve plug will not move at this time.
  - b. Apply a 1V signal between pins 3 and 4 – valve plug will move to the upper stop, immediately followed by moving to the lower, closed position.
  - c. If calibration of the analog input is desired to improve positional accuracy, an optional operation is listed in the next section titled Analog Input Calibration.
8. The unit is now calibrated.

## Analog Input Calibration

Improved positional accuracy may be obtained by calibrating the actuator to the analog signal input. The position of the valve plug is linearly proportional to the analog control signal end points, with 4 mA/1V equating to fully closed and 20 mA/5V equating to fully open.

1. Apply a 4 mA or 1V signal between pins 3 and 4 - valve plug will move to the fully open position.
2. Send a value of 1 to register 40004 or click Analog Cal at 0% in the configuration software.
3. Apply a 20 mA or 5V signal between pins 3 and 4 - valve plug will move to the fully closed position.
4. Send a value of 1 to register 40005 or click Analog Cal at 100% in the configuration software.
5. The unit is calibrated to your analog signal.

## Start Up

### WARNING

To avoid personal injury or property damage, be aware that the valve will move and respond to an input signal during start up.

1. Before turning on power to the unit, be sure that a closed signal is being commanded to the unit.
  - Dry-Contact: contact is open.
  - L2e (Dual Dry Contact): Contact closed across pins 1 & 3.
  - Analog Input: signal < 4mA or 1V.
  - Modbus: position demand = 0.
2. Turn on power to the unit.
3. Apply a change in position demand to ensure unit responds properly.

- Dry-Contact:
    - Closed contact between pins 1 & 2 will open the valve.
    - Dual contact / L2e only (40043=0) : Closed contact between pins 1 & 2 will open the valve. Closed contact between pins 1 & 3 will close the valve.
  - Analog Input: valve will respond to proportional demand.
  - Modbus: valve will respond to positional demand in register 40001. 0 = fully closed and 100 = fully open.
4. If the valve does not respond as expected, proceed to Troubleshooting guide on page 14.
  5. Check conduit ports.
    - Conduit seal must be in place within 450mm (18 inches) of the enclosure.
    - Unused conduit ports must be sealed with an explosion-proof port plug.
  6. Replace the cover and tighten all 8 bolts to 20 N-m (15 ft-lbs).

## Troubleshooting

1. Unit does not move.
  - a. Verify that 12VDC to 24VDC is present on the power terminals as shown on the cover.
  - b. Verify that all wires are firmly attached on both ends.
  - c. Verify that wires are connected to the correct terminals - see Wiring in the manual.
  - d. Verify mode of operation (on/off or positioning) matches control signal.
  - e. Verify mode of control (local or Modbus) matches control signal.
2. Unit does not respond to 4-20mA signal
  - a. Verify that 12VDC to 24VDC is present on the power terminals as shown on the cover.
  - b. Verify that the 4-20mA signal is wired correctly and that the terminals are firmly on the wires.
  - c. Verify mode of operation matches control signal (local control: 40033=0, positioning: 40034=1).
  - d. Check the value of the analog input in register 40025 (middle right of configuration software screen) to determine if it is 0 or greater.
    - i. If register 40025 shows 0 and the circuit board is green (not blue), it is possible a 4-20mA signal was applied without power to the power terminals and damage to the input circuitry has occurred. Contact your Emerson Process Management sales office for further information.
3. Unit moves to fully open when 1V signal is applied and closed when 5V signal is applied.
  - a. Unit is likely configured as an on/off unit with local control; on/off units can not be controlled as an analog device.
    - i. If on/off control is desired, use a dry contact switch to control in local mode or change to Modbus mode to control the unit.



- ii. If positioning control is desired, contact your Fisher Local Business Partner to upgrade your actuator to positioning control.
4. Diagnostics show a Motor Stall Fault.
- a. The easy-Drive electric actuator is designed to operate in a manner consistent with a pneumatic actuator. This means that if the valve plug can not move to its commanded position, the actuator will stop, without damage, and issue a Motor Stall Fault warning. When the command signal changes outside of the deadband (Modbus register 40036), it will attempt to move again. Recalibrate the actuator span per instructions in the Startup section of this manual.
5. Position on D3 is not accurate (proportional positioning units only).
- a. If the position of a D3 is too high (i.e. 50% is much higher than 50% on the bonnet), check the valve type. If valve type is D4, change to D3, cycle power, and recalibrate.
  - b. If the local analog input is being used (4-20mA or 1-5V), the analog inputs of the actuator may be calibrated to match the input signal.
    - i. Command 0% (4mA or 1V).
    - ii. Using a Modbus link, send a 1 to register 40004 or use the Fisher easy-Drive configuration software by clicking the button "Analog Cal at 0%".
    - iii. Command 100% (20mA or 5V).
    - iv. Using a Modbus link, send a 1 to register 40005 or use the Fisher easy-Drive configuration software by clicking the button "Analog Cal at 100%".

Figure 9. Adjusts to Vary Flow Capacity (Shown with Valve Plug in Seated Position)

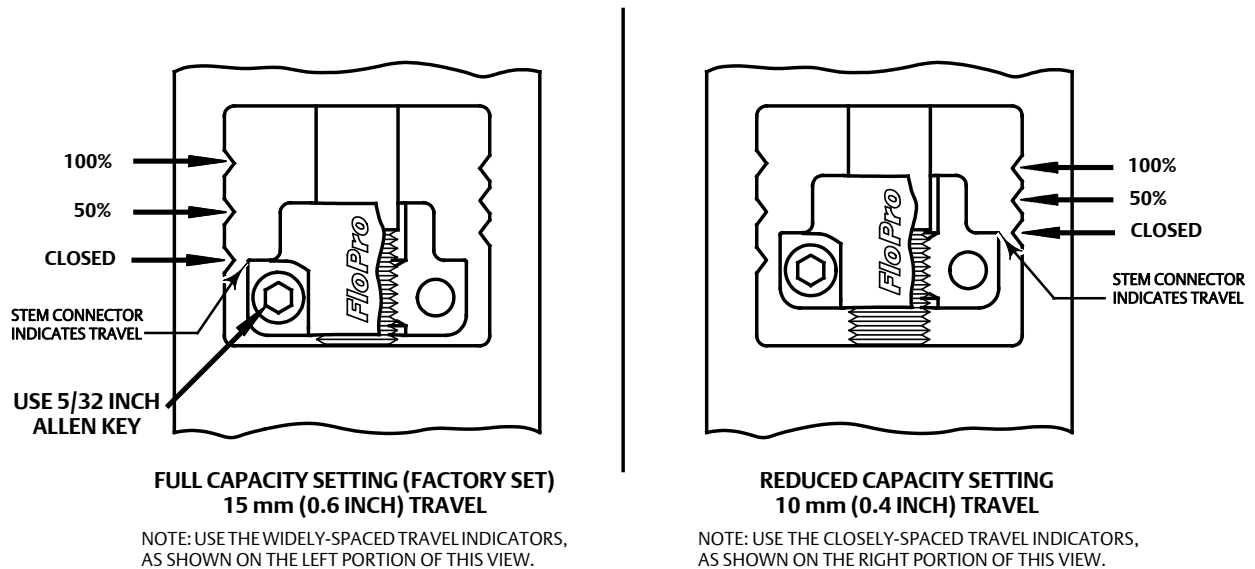

## Setting the Valve Flow Adjuster

The flow setting may only be adjusted if the 0.375 and 0.75 inch port sizes are installed and only when using the on/off version.

When shipped from the factory, the actuator has the flow adjuster set at the maximum flow rate position for the given port size.

1. Ensure the valve plug is in the seated position.
2. To change the valve flow rate, loosen the flow adjuster socket head cap screws (key 15) with a 5/32 inch Allen key, and reposition the flow adjuster halves (key 13 and 14) to the desired flow rate position. See figure 9 for flow rate settings.
3. Retighten the socket head screws (key 15) to 3 N•m (26 lbf•in).
4. Follow instructions for recalibration on page 10.

## Maintenance

Refer to figure 12.

Valve parts are subject to normal wear and must be inspected and replaced as necessary. The frequency of inspection and maintenance depends on the severity of the service conditions.

### **⚠ WARNING**

**Avoid personal injury from sudden release of process pressure or bursting of parts. Before performing any maintenance operations:**

- Do not remove the actuator from the valve while the valve is still pressurized.
- Always wear protective gloves, clothing, and eyewear when performing any maintenance operations to avoid personal injury.
- Disconnect any operating lines providing electric power, or a control signal to the actuator. Be sure the actuator cannot suddenly open or close the valve.
- Use bypass valves or completely shut off the process to isolate the valve from process pressure. Relieve process pressure on both sides of the valve. Drain the process media from both sides of the valve.
- Use lock-out procedures to be sure that the above measures stay in effect while you work on the equipment.
- The valve packing box may contain process fluids that are pressurized, *even when the valve has been removed from the pipeline*. Process fluids may spray out under pressure when removing the packing hardware or packing rings.
- Check with your process or safety engineer for any additional measures that must be taken to protect against process media.

### **⚠ WARNING**

For explosion-proof applications, ensure the actuator cover is properly bolted before applying power to the actuator. Personal injury or property damage may result from fire or explosion if power is applied to the actuator with the cover removed in a hazardous area.

Do not remove the actuator cover for 10 minutes after power is disconnected if the UPS option is installed.

For explosion-proof applications, install rigid metal conduit and a conduit seal no more than 457 mm (18 inches) from the transducer. Personal injury or property damage may result from explosion if the seal is not installed.

Select wiring and/or cable glands that are rated for the environment of use (such as hazardous area, ingress protection, and temperature). Failure to use properly rated wiring and/or cable glands can result in personal injury or property damage from fire or explosion.

Wiring connections must be in accordance with local, regional, and national codes for any given hazardous area approval. Failure to follow the local, regional, and national codes could result in personal injury or property damage from fire or explosion.

Figure 10. Packing and Belleville Spring Stacking Order

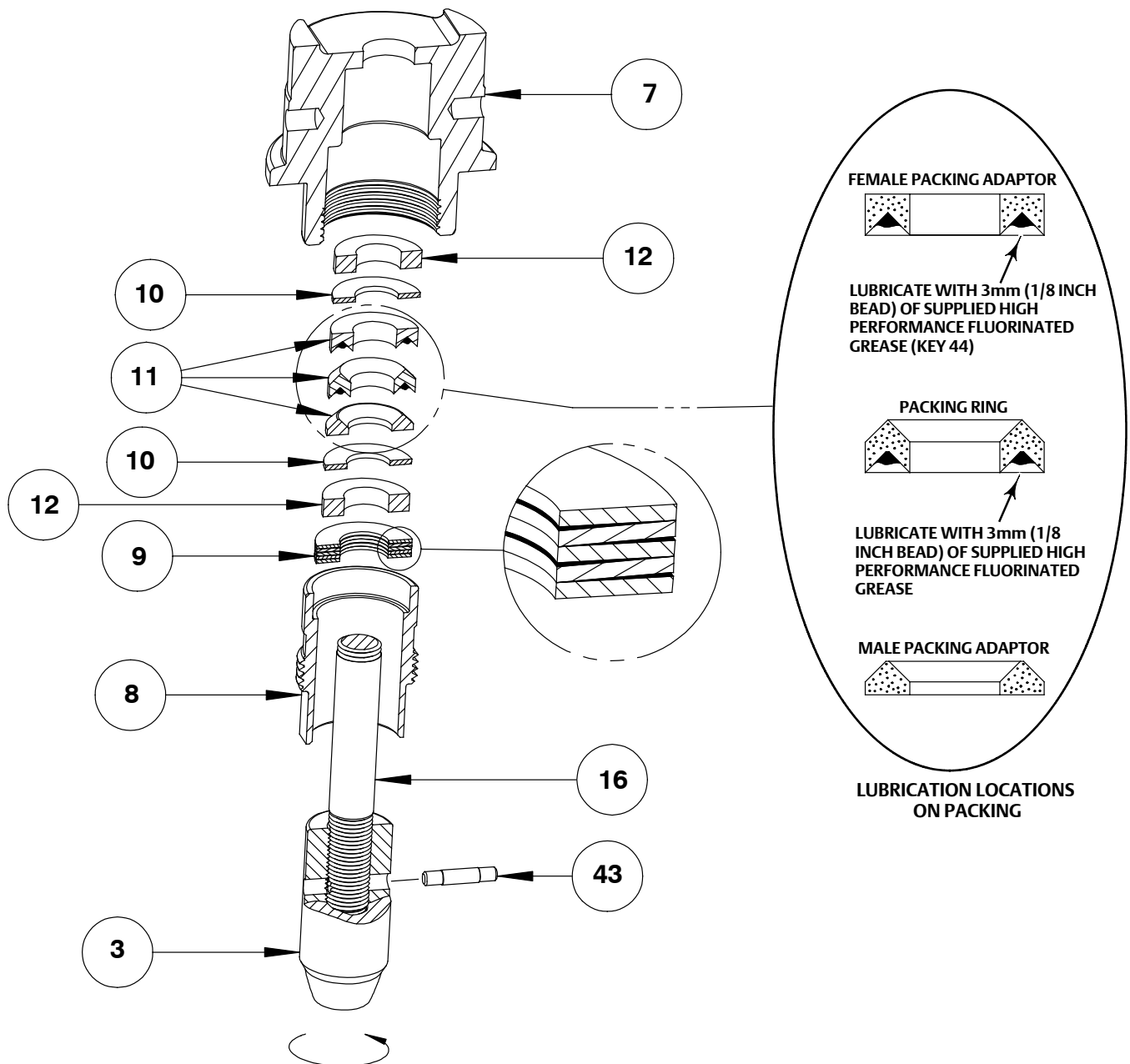
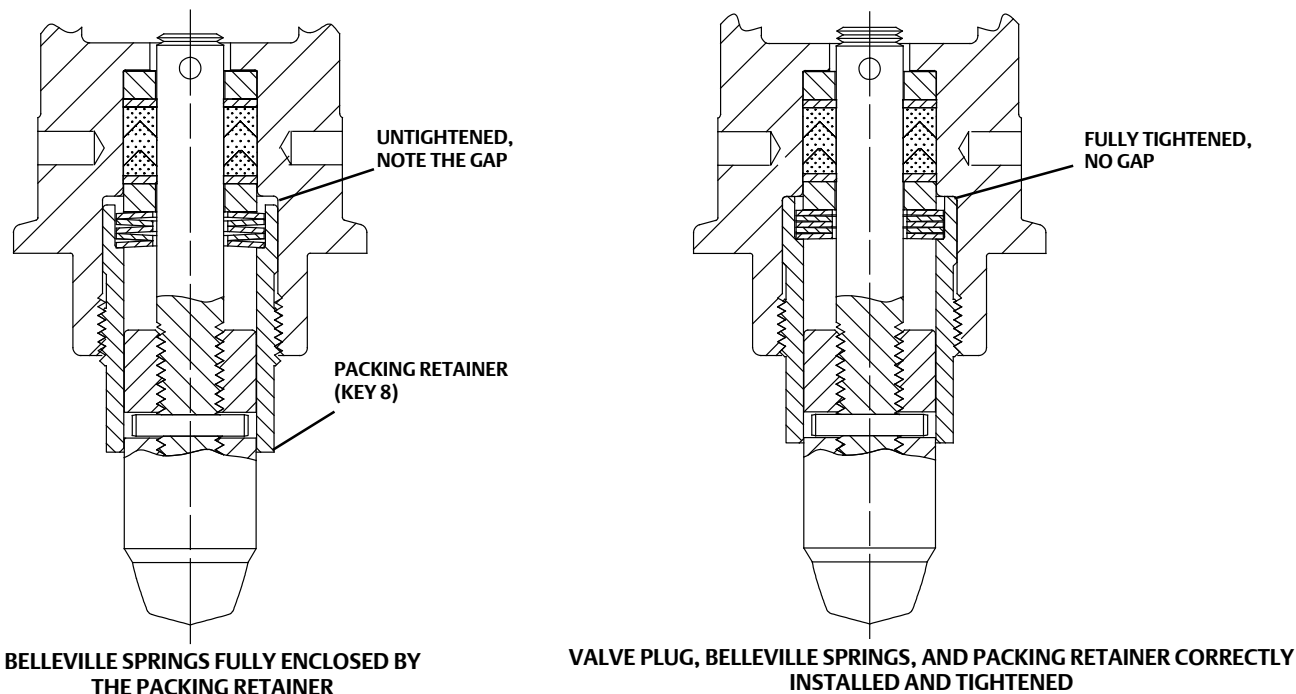

Figure 11. Packing and Belleville Spring Stacking Order



## Valve Plug and Seat Ring Maintenance Trim Disassembly

Key numbers are referenced in figures 10, 12, and 13.

1. Isolate the control valve from the line pressure, release pressure from both sides of the valve body (key 1), and drain the process media from both sides of the valve.

### CAUTION

The following steps are intended to prevent damage to the valve plug (key 3) and seat ring (key 2) during the removal of the bonnet and actuator.

#### For ON/OFF Actuators

2. Command the valve open.
3. Place an open end wrench or a similar obstruction about 6 mm (1/4 inch) thick under the FloPro.
4. Command the valve closed.

#### For Positioning Actuators

5. Command the valve to anywhere between 10% and 20% travel.
6. Isolate power and signal.

7. Break the bonnet nut (key 5) loose with a hammer. Continue turning the bonnet nut by using a hammer or a large adjustable wrench, tightened around one ear of the bonnet nut. If the bonnet (key 7) is stuck in the valve, continue to unscrew the bonnet nut. The bonnet nut will contact the spring pins (or pipe plugs) (key 6, figure 12) and jack the bonnet out of the valve. Carefully lift the actuator assembly from the valve body.

### **⚠ WARNING**

**The spring pins/pipe plugs (key 6) must always be in place during valve operation. They provide a safeguard against injury when the unit is being disassembled.**

8. Completely remove the packing retainer (key 8) using a 1-1/8 inch wrench.
9. Remove the valve plug by driving out the pin (key 43) and unscrewing the valve plug from the stem. Do not remove the Belleville springs (key 9) from the stem, in order to retain the Belleville stacking orientation as shown in figure 10.
10. Use a 1-3/16 inch socket wrench to loosen and remove the seat ring (key 2).

### **CAUTION**

**Inspect the seat ring and valve body interior for wear, erosion, or damage in the following steps.**

11. Inspect the seat ring for wear or damage. If the seating surface has been damaged, discard the seat ring.
12. Visually inspect the valve body interior below the seat ring for erosion or damage. Replace the valve body if necessary.

### **⚠ WARNING**

**Be careful to avoid damaging the seating surface on the valve plug or seat ring as damage in these areas will allow excessive leakage at shutoff. Avoid damaging the highly polished valve stem surface. A damaged valve stem could cut the packing and allow process fluid to leak to the atmosphere.**

**Cover the opening in the valve body to prevent foreign material from getting into the valve body cavity.**

## **Trim Assembly**

1. Ensure the threads of the valve stem (key 16) and valve plug (key 3) are clean and free of debris.
2. Make sure the Belleville springs (key 9) are properly installed on the valve stem, as shown in figure 11.
3. Install the valve plug on the stem and insert a new pin (key 43).
4. Lubricate the threads of the packing retainer with anti-seize and install into the bonnet using a 1-1/8 inch wrench. Make sure the Belleville springs (key 9) are completely enclosed by the packing retainer as shown in figure 11.
5. Torque the packing retainer to 81 N•m (60 lbf•ft). The packing retainer has been installed correctly when a metal-to-metal contact has been made between the packing retainer end and the bonnet (key 7). The packing retainer threads should be completely enclosed by the bonnet (see figure 11).
6. Thoroughly clean the seat ring (key 2) threads and the mating threads in the valve body (key 1).
7. Apply anti-seize lubricant to the threads of the seat ring and its mating threads in the valve body.
8. Screw the seat ring into the valve body. Use a 1-3/16 inch socket wrench to tighten the seat ring to 170 N•m (125 lbf•ft). Remove all excess lubricant after tightening.
9. Lubricate the bonnet O-ring (key 4) with lithium grease and install on the bonnet.

10. Apply anti-seize lubricant to the threads on the valve body and bonnet nut (key 5) and the contact surfaces of the bonnet and bonnet nut flange. Install the bonnet and actuator assembly onto the valve body. Tighten the bonnet nut until the nut stops turning. A few hammer blows will be required to ensure that the assembly is tight.

## Packing Maintenance

### **▲ WARNING**

Observe the warning at the start of the Maintenance section.

Key numbers are referenced in figure 10.

The valve stem packing can only be serviced by removing the bonnet from the valve body.

### Packing Disassembly

1. Disassemble the valve per steps 1 - 9 in the Trim Disassembly section of the Valve Plug and Seat Ring Maintenance section of this manual.
2. Remove the five Belleville springs (key 9), lower packing spacer (key 12), packing set (key 11), and two anti-extrusion washers (key 10) from the bonnet (key 7) using a formed wire hook.
3. Clean and inspect the packing box wall to ensure that the packing surfaces are not damaged. If the surface condition is damaged and cannot be improved by light sanding, replace the bonnet.
4. Inspect the valve stem (key 16) and valve plug (key 3) for scratches or wear and replace if necessary.

### Packing Assembly

The following steps define the proper procedure for installing the packing in a D3 valve. Improper packing assembly can lead to poor valve performance. The proper packing arrangement is shown in figures 10 and 11.

1. Ensure the upper packing spacer (key 12) is installed.
2. Use the lower packing spacer (key 12) and a tube to push the upper anti-extrusion washer (key 10) into place. Using the lower packing spacer in this manner will ensure the upper anti-extrusion washer is fully seated and flat when installed in the packing bore.
3. Remove the lower packing spacer from the packing bore.

### **CAUTION**

All D3 packing kits include a single use packet of high performance fluorinated grease. This is the only acceptable D3 packing lubricant.

#### Note

In the following procedure, carefully install each packing ring individually over the valve stem and push completely into the packing box with a non-marring tube. A 12-inch length of 1/2 inch PVC pipe works well for this. It is recommended that the lubricated packing rings be installed individually rather than pushed in as a set.

4. Apply a 3mm (1/8 inch) bead of the supplied high performance fluorinated grease (key 44) around the groove of the female packing adaptor as shown in figure 10 and install over the valve stem (key 16).
5. Apply a 3mm (1/8 inch) bead of the supplied high performance fluorinated grease (key 44) around the groove of the packing ring as shown in figure 10 and install over the valve stem.

6. Install the male packing adaptor, lower anti-extrusion washer (key 10), and lower packing spacer over the valve stem as shown in figure 10.
7. Firmly press all packing parts into the packing bore with a tube.
8. Install the five Belleville springs (key 9) over the valve stem as shown in figure 10.
9. Install the valve plug (key 3) on the stem and insert a new groove pin (key 43).
10. Lubricate the threads of the packing retainer with anti-seize and install into the bonnet using a 1-1/8 inch wrench. Make sure the Belleville springs are completely enclosed by the packing retainer as shown in figure 11.
11. Torque the packing retainer to 81 N•m (60 lbf•ft). The packing retainer has been installed correctly when a metal-to-metal contact has been made between the packing retainer end and the bonnet (key 7). The packing retainer threads should be completely enclosed by the bonnet.
12. Apply anti-seize lubricant to the threads on the valve body and bonnet nut (key 5) and the contact surfaces of the bonnet and bonnet nut flange. Install the bonnet and actuator assembly onto the valve body. Tighten the bonnet nut until the nut stops turning. A few hammer blows will be required to ensure that the assembly is tight.

## Stem Replacement

### CAUTION

**If the valve stem is replaced, the packing will also need to be replaced, since the threads on the valve stem may damage the packing when the valve stem is removed.**

1. Follow the Trim Disassembly procedures, steps 1-8 on page 18 of this manual.
2. Ensure power and signal have been isolated from the actuator. Open the explosion-proof enclosure (keys 60 and 61), using a 13mm wrench.
3. Remove the FloPro (keys 13, 14, and 15), using a 5/32 inch hex head wrench.
4. Remove the stem nut (key 27), using an 11/16 inch wrench, noting the position of the FloPro relative to the bonnet markings.
5. Use a rubber mallet to gently drive the stem downward through the bottom of the actuator housing and remove the stem.
6. Ensure the packing has been removed, using procedures in the Packing Disassembly on page 20 of this manual.
7. Replace the stem by gently pushing the stem up through the actuator.
8. Replace the packing and plug, using the procedures in the Packing Assembly on page 20 of this manual.
9. Install the FloPro at the same position it was removed from in step 4. Tighten the hex socket head cap screws to 3 N•m (26 lbf•in).
10. Tighten the stem nut (key 27) to 39 N•m (29 lbf•ft) using an 11/16 inch wrench. Be sure the FloPro is not allowed to rotate when tightening the stem nut.
11. Apply anti-seize lubricant to the threads on the valve body and bonnet nut (key 5) and the contact surfaces of the bonnet and bonnet nut flange. Install the bonnet and actuator assembly onto the valve body. Tighten the bonnet nut until the nut stops turning. A few hammer blows will be required to ensure that the assembly is tight.

## Parts Ordering

Each D3 control valve is assigned a serial number, which can be found on the nameplate. Refer to the number when contacting your Emerson Process Management representative for assistance or when ordering replacement parts.

### **⚠ WARNING**

**Use only genuine Fisher replacement parts. Components that are not supplied by Emerson Process Management should not, under any circumstances, be used in any Fisher valve, because they may void your warranty, might adversely affect the performance of the valve, and could cause personal injury and property damage.**

## Parts Kits

TRIM KITS	Port Diameter (inches)	0.375	0.75	1
	Standard trim kit (Contains keys 2, 3, 4, and 43)		RD3STD0012	RD3STD0022
Carbide trim kit (Contains keys 2, 3, 4, and 43)		RD3CARB042	RD3CARB052	RD3CARB062

<b>PACKING KIT</b>	Contains keys 4, 10, 11, 43, and 44	RD3PACK012
--------------------	-------------------------------------	------------

<b>VALVE STEM</b>	Key 16	GE48049X012
-------------------	--------	-------------

## Parts List

### Note

Recommended spare parts are included in the Parts Kits shown at the top of this page. For additional information or for part numbers not shown, contact your Emerson Process Management sales office.

### Key Description

1	Valve Body
2*	Seat Ring
3*	Valve Plug
4*	Bonnet O-ring
5	Bonnet Nut
6	Spring Pin (or alternate pipe plug) (2 req'd)
7	Bonnet
8	Packing Retainer
9	Belleville Springs (5 req'd)
10*	Anti-Extrusion Washer (2 req'd)
11*	Packing Set

### Key Description

12	Packing Spacer
13	FloPro Half
14	FloPro Half
15	Hex Socket Head Cap Screw (2 req'd)
16*	Stem
18	O-ring
20	Locknut
25	Stem O-ring
27	Stem Nut
34	Valve Nameplate
41	Drive Screw (2 req'd)
43*	Groove Pin
44*	High Performance Fluorinated Grease Packing Lubricant
58	Enclosure O-ring
59	Motor/gearbox/controller assembly
60	Upper Enclosure
61	Lower Enclosure
62	Motor Cap Screws (4 req'd)
63	Motor Cap Screw Washers (4 req'd)
64	Enclosure Cap Screws (8 req'd)
65	Enclosure Cap Screw Retaining Washers (8 req'd)
66	Ground Screw
68	Certification Nameplate
69	easy-Drive Label
70	Uninterruptable Power Supply



Figure 12. D3 Valve Assembly

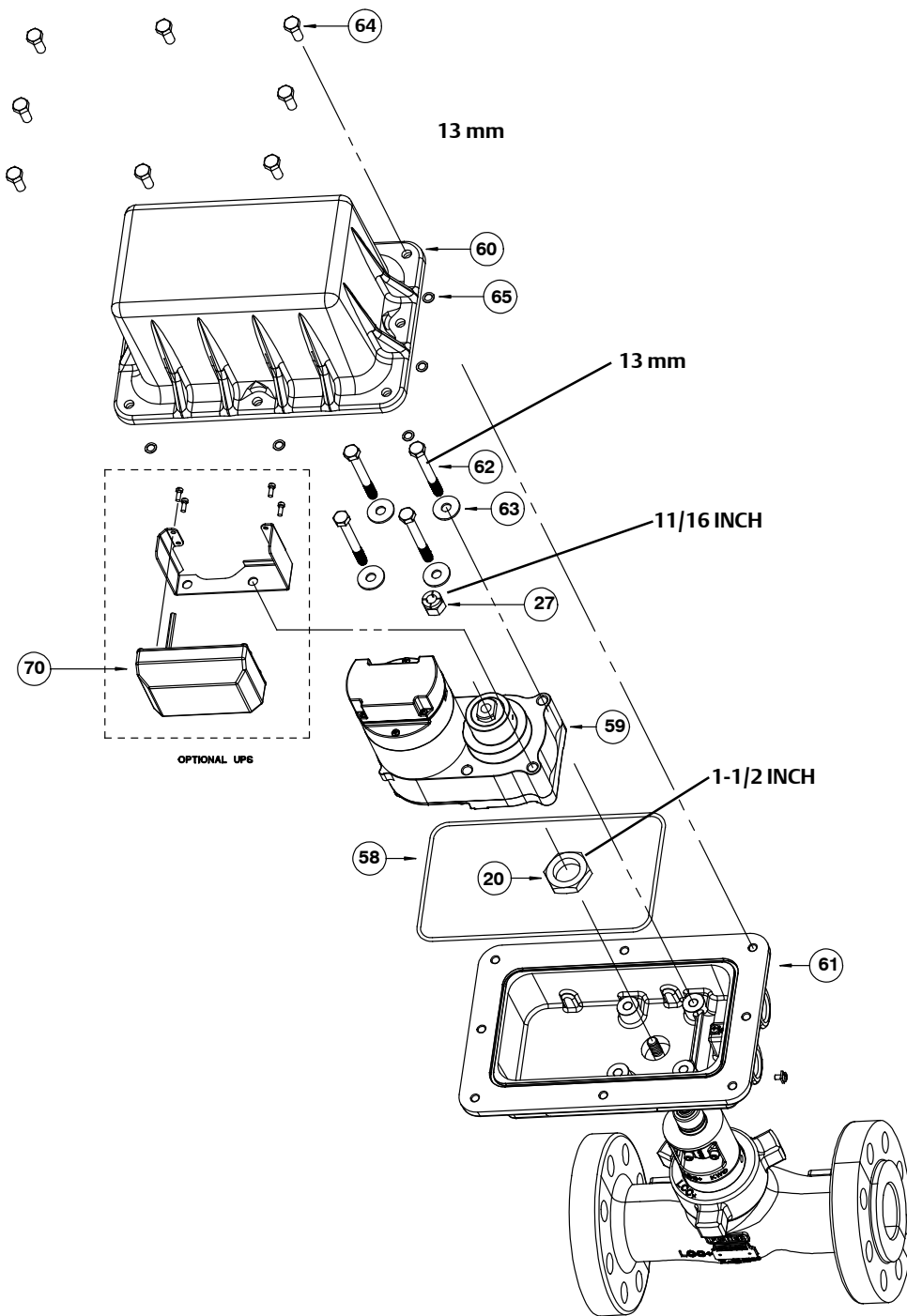
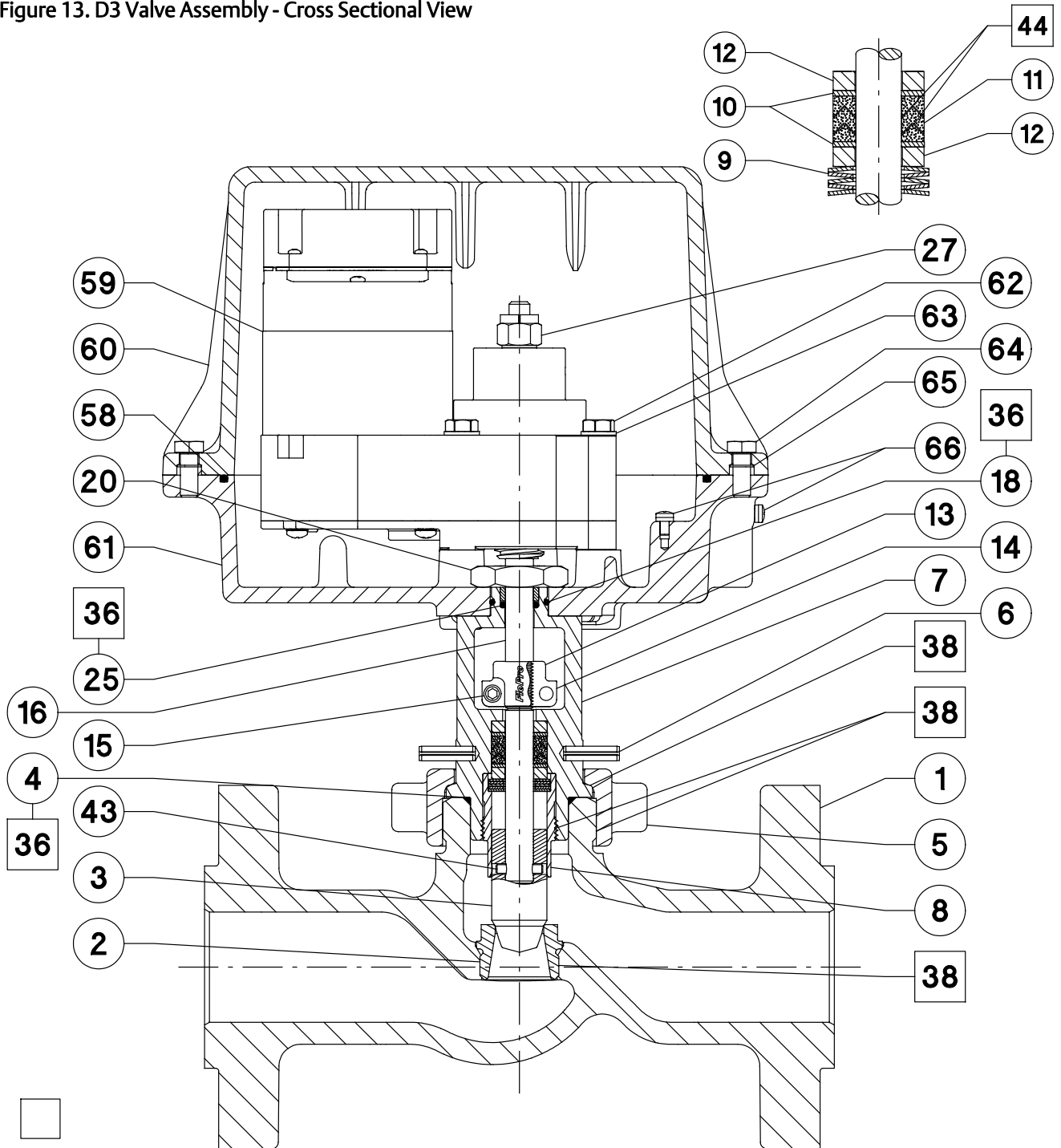

Figure 13. D3 Valve Assembly - Cross Sectional View



  
**APPLY LUBRICANT**  
 GE49376-B

## Appendix A - Modbus

### A.1 Register Summary

Table 4. Register Summary

DATA	LEGAL FUNCTION CODES	REGISTER (PHYSICAL)	TYPE	R/W	DESCRIPTION
Position Demand – Proportional	03 – Read Holding Reg 06 – Write Single Reg 16 – Write Multiple Reg	40001 (0x0000)	UINT16	R/W	Value 0-100 = 0-100% Position
Reset Diagnostics	03 – Read Holding Reg 06 – Write Single Reg 16 – Write Multiple Reg	40002 (0x0001)	UINT16 (BOOL)	R/W	0 = Reset Idle, 1 = Reset Active
Recalibrate Demand	03 – Read Holding Reg 06 – Write Single Reg 16 – Write Multiple Reg	40003 (0x0002)	UINT16	R/W	0 = Idle, 1 = Reset calibration request – unit will reset to non calibrated state and await calibration sequence
Analog Cal at 0%	03 – Read Holding Reg 06 – Write Single Reg 16 – Write Multiple Reg	40004 (0x0003)	UINT16	R/W	0 = Idle, 1 = Calibrate at 0%
Analog Cal at 100%	03 – Read Holding Reg 06 – Write Single Reg 16 – Write Multiple Reg	40005 (0x0004)	UINT16	R/W	0 = Idle, 1 = Calibrate at 100%
Reserved	03 – Read Holding Reg	40006 (0x0005)	UINT16	R	Read will return power up default of 0
Reserved	03 – Read Holding Reg	40007 (0x0006)	UINT16	R	Read will return power up default of 0
Reserved	03 – Read Holding Reg	40008 (0x0007)	UINT16	R	Read will return power up default of 0
Test Register	03 – Read Holding Reg	40009 (0x0008)	UINT16	R	Read will return power up default of 45964 decimal (Binary/Hex -0b10110001110001100 / 0xB38C)
Actual Position	03 – Read Holding Reg	40010 (0x0009)	UINT16	R	Value 0-100 = 0-100% Position
Actual Demand	03 – Read Holding Reg	40011 (0x000A)	UINT16	R	Value 0-100 = 0-100% is demand to position loop from active control source
Diagnostic Flags	03 – Read Holding Reg	40012 (0x000B)	UINT16	R	Bit Flags – see Description in section A.2 and table 5
Number of cycles	03 – Read Holding Reg	40013 (LSW) (0x000C)	UINT32†	R	Number of movements
		40014 (MSW) (0x000D)			
Hours Running	03 – Read Holding Reg	40015 (LSW) (0x000E)	UINT32†	R	Total hours powered - version 4.13 Total minutes powered - version 4.21
		40016 (MSW) (0x000F)			
Hours Open	03 – Read Holding Reg	40017 (LSW) (0x0010)	UINT32†	R	Total hours in open position (at 100%) - version 4.13 Total minutes in open position (at 100%) - version 4.21
		40018 (MSW) (0x0011)			
Hours Closed	03 – Read Holding Reg	40019 (LSW) (0x0012)	UINT32†	R	Total hours in closed position (at 0%) - version 4.13 Total minutes in closed position (at 0%) - version 4.21
		40020 (MSW) (0x0013)			
Number of power up cycles	03 – Read Holding Reg	40021 (LSW) (0x0014)	UINT32†	R	Number of times power is cycled successfully
		40022 (MSW) (0x0015)			
Serial Number	03 – Read Holding Reg	40023 (LSW) (0x0016)	UINT32†	R	Product Unique Identifier 0-4294967295
		40024 (MSW) (0x0017)			
Analog I/P Value	03 – Read Holding Reg	40025 (0x0018)	UINT16	R	0-50 = 0-5V (Voltage mode I/P) 0-200 = 0-20mA (Current Loop I/P)
Firmware Project Code	03 – Read Holding Reg	40026 (0x0019)	UINT16	R	Project code
Firmware Document Reference	03 – Read Holding Reg	40027 (0x001A)	UINT16	R	Document reference
Firmware Version	03 – Read Holding Reg	40028 (0x001B)	UINT16	R	Version, MSB 8bits = major, LSB 8bits = minor
Diagnostic Flags History	03 – Read Holding Reg	40029 (0x001C)	UINT16	R	Bit Flags – see Description in section A.2. – This is a history of any faults that have occurred and is stored in memory
Reserved	03 – Read Holding Reg	40030 (0x001D)	UINT16	R	Read will return power up default of 0

-continued-

Table 4. Register Summary (continued)

DATA	LEGAL FUNCTION CODES	REGISTER (PHYSICAL)	TYPE	R/W	DESCRIPTION
Reserved	03 – Read Holding Reg	40031 (0x001E)	UINT16	R	Read will return power up default of 0
Valve type	03 – Read Holding Reg 06 – Write Single Reg 16 – Write Multiple Reg	40032 (0x001F)	UINT16	R/W	1 = D3, 2 = D4
Control Type	03 – Read Holding Reg	40033 (0x0020)	UINT16	R	0 = On/Off, 1 = Proportional
Control Source	03 – Read Holding Reg 06 – Write Single Reg 16 – Write Multiple Reg	40034 (0x0021)	UINT16	R/W	0 = Modbus RTU Register Commands, 1 = Local Control
Loss of control input/comms default position	03 – Read Holding Reg 06 – Write Single Reg 16 – Write Multiple Reg	40035 (0x0022)	UINT16	R/W	Value 0-100 = 0-100% Position Valve 101 - Last Position
Deadband	03 – Read Holding Reg 06 – Write Single Reg 16 – Write Multiple Reg	40036 (0x0023)	UINT16	R/W	Value 0-100 = 0-100% Level of hysteretic dead band applied to position control demand
Low travel cutoff	03 – Read Holding Reg 06 – Write Single Reg 16 – Write Multiple Reg	40037 (0x0024)	UINT16	R/W	Blanking from zero position in percent
Communications Timeout	03 – Read Holding Reg 06 – Write Single Reg 16 – Write Multiple Reg	40038 (0x0025)	UINT16	R/W	Timeout in seconds before loss of communications state is asserted
Communications Address	03 – Read Holding Reg 06 – Write Single Reg 16 – Write Multiple Reg	40039 (0x0026)	UINT16	R/W	Modbus address in the range 1-247 (Default = 1)
Communications Baudrate	03 – Read Holding Reg 06 – Write Single Reg 16 – Write Multiple Reg	40040 (0x0027)	UINT16	R/W	0 = 300 Baud, 1 = 600 Baud, 2 = 1200 Baud, 3 = 2400 Baud, 4 = 4800 Baud, 5 = 9600 Baud, (Default) 6 = 19200 Baud, 7 = 38400 Baud
Parity	03 – Read Holding Reg 06 – Write Single Reg 16 – Write Multiple Reg	40041 (0x0028)	UINT16 (BOOL)	R/W	0 = Odd, 1 = Even, 2 = None ("None" available in version 4.21 only)
Reset Statistics	03 – Read Holding Reg 06 – Write Single Reg 16 – Write Multiple Reg	40042 (0x0029)	UINT16 (BOOL)	R/W	0 = Reset Idle, 1 = Reset Active
Local Control Mode	03 – Read Holding Reg 06 – Write Single Reg 16 – Write Multiple Reg	40043 (0x002A)	UINT16	R/W	On/Off 0 = L2e dual dry contact 1 = Single dry contact Proportional 0 = 1-5V 1 = 4-20 mA

UINT16 – unsigned 16 bit variable, can take value 0-65535.

UINT32 – unsigned 32 bit variable, can take value 0-4294967295.

(Reserved) – registers used for development use only.

† - 32bit register contains data that spans two registers – reads and write of data needs to be performed within the same Modbus command function to ensure coherency of data.

**Table 5. Fault Register – Fault Flags Summary Table**

Diagnostic Flags – Bit Mask Value	Diagnostic Flags – Binary Mask Value	Description
0x8001	1000 0000 0000 0000	Fault in N.V. Memory – system has restored default settings
0x4000	0100 0000 0000 0000	Motor assembly stall
0x2000	0010 0000 0000 0000	Speed measurement fault
0x1000	0001 0000 0000 0000	System or Watchdog fault
0x0800	0000 1000 0000 0000	Overspeed condition
0x0400	0000 0100 0000 0000	Calibration span not in legal range
0x0200	0000 0010 0000 0000	Fault in N.V. Memory – system has recovered settings
0x0100	0000 0001 0000 0000	Communications Timeout
0x0080	0000 0000 1000 0000	Valve was shutdown while moving
0x0040	0000 0000 0100 0000	Valve span calibrated (informational)
0x0020	0000 0000 0010 0000	Valve position controller active (informational)
0x0010	0000 0000 0001 0000	Analog input – below 3mA/0.75V (informational)
0x0008	0000 0000 0000 1000	Motor Overspeed coast condition
0x0004	0000 0000 0000 0100	Modbus command has been sent (starts a calibrated system)
0x0002	0000 0000 0000 0010	Analog input initialized (system has seen input >3mA/1V)
0x0001	0000 0000 0000 0001	Start delay active (within 10 second calibration window)

## A.2 Diagnostic Flags

The diagnostic register holds a 16 bit value that represents 16 individual flags, when set (value ‘1’), this indicates the following conditions have occurred or are still present, the highest 7 bits are latching and will be present in the register even if the initial cause for the flag being set is removed. If these flags are set, a reset needs to be performed to clear the fault.

### A.2.1 Fault in NV Memory

This is a severe fault and is usually seen when the firmware is upgraded with a program that uses a different EEPROM/Non-volatile memory map. If this is not the case then the probable cause is a fault in the memory hardware.

### A.2.2 Motor Assembly Stall

The valve plug was unable to move to the commanded position. The drive has attempted to move the motor by applying a non-zero PWM signal, and the speed has not been detected as greater than 0 with a 400ms period. This fault latches and needs to be reset.

### A.2.3 Speed Measurement Fault

The controller detected pulses that correspond to the motor going much faster than the speed the speed measurement system is designed for – the integrity of the measurement cannot be relied upon. This fault latches and needs to be reset.

### A.2.4 System or Watchdog Fault

The software system has been reset and this flag is set at power up if the case of the reset was the onboard watchdog either timing out OR being forced by program function call. This flag is used as an indication that this type of reset has occurred.

### A.2.5 Overspeed Condition

The drive speed was detected as being over the speed 3300RPM. This fault latches and needs to be reset.

### A.2.6 Calibration Span Not in Legal Range

Following a calibration the detected mechanical travel was detected as being too short for the valve type. This fault latches and needs to be reset.

### A.2.7 Fault in NV Memory – recovered settings

This fault is similar to Fault in NV Memory but is different in that the settings were recovered, however it is possible the fault was due to a setting being changed during a power cycle. The settings need to be validated before valve operation.

### A.2.8 Communications Timeout

This flag is set after a timeout or loss of valid communications, it will be cleared if communications is reestablished with the valve controller. If this flag is set and the control demand is set to be taken from the Modbus then the valve will be commanded to the 'Loss of communications position' in setting accessed at Modbus register 40034.

### A.2.9 Valve was Shutdown while Moving

The valve was actuating while power was removed, the position information may be unreliable. Command valve to 0% to assure position information is accurate.

### A.2.10 Valve Span Calibrated

The valve is calibrated.

### A.2.11 Valve Position Controller Active

The valve is being actively controlled to go to a demanded position. The speed and position control loop logic is setting the pwm and direction demands to the ValuDrive motor.

### A.2.12 Analog Input Below 3mA/0.75V

The analog input is below a set threshold of 3mA. If since being powered up this level has been met the flag 'Analog input initialized' will be set. If the control source is the analog input and this flag is set then the valve will be commanded to actuate to the 'Loss of control input' position.

### A.2.13 Motor Overspeed Coast Condition

The drive speed was detected as being over the speed 2500RPM. The flag is cleared if the speed falls below the coast threshold level. This flag is used purely as a diagnostic.

### A.2.14 Modbus Command Initialized

The system has received a command to the Position demand register since being powered up. If Modbus is the selected control mode the valve will be commanded to this position after the startup period.

## A.2.15 Analog Input Initialized

The analog input has been detected as having a control signal within the expected range of 3-20mA. If the analog input is the selected control signal then this will activate the valve after the startup period.

## A.2.16 Start Delay Active

This is a flag set during the startup phase of operation, if this is set then the valve may be recalibrated by sending the calibration signal sequence (100% demand followed by 0%). It is cleared to indicate normal operation (recalibration will then require a command to Modbus register 40003).

## A.3 Register Description

### A.3.1 40001 Position Demand – Proportional [Read & Write]

Register: 40001, Address 0x0000 (0).  
 Function code: 0x10 – Write Multiple registers, 0x06 – Write Single register, or 0x03 – Read Holding registers.  
 Description: This is a value between 0 and 100% to demand a valve position. This register will only be used by the system if the control source (set by register 40035) is set for Modbus RTU control. If the control type (set by register 40034) is On/Off then value will be resolved with a boolean set operation for a Open/Closed position demand variable output (e.g. Values 0-49 = '0' and 50-100 = '100'). This variable needs to be set to 100% then 0% after a power-up to calibrate an un-calibrated system.

### A.3.2 40002 Reset Diagnostics [Read & Write]

Register: 40002, Address 0x0001 (1).  
 Function code: 0x10 – Write Multiple registers, 0x06 – Write Single register, or 0x03 – Read Holding registers.  
 Description: This is a modbus request to reset the system from a fault state (indicated if the Diagnostics flags register has any set faults). Writing a decimal 1 to the register will start a reset process only if the system has a fault, otherwise the write will be ignored. Once the fault reset request has been acknowledged the register will be set to decimal 0. Bit assignments are shown in table 5.

### A.3.3 40003 Recalibrate Demand [Read & Write]

Register: 40003, Address 0x0002 (2).  
 Function code: 0x10 – Write Multiple registers, 0x06 – Write Single register, or 0x03 – Read Holding registers.  
 Description: Writing a value of 1 to this register will force the system to clear any calibration information and go through a cycle of calibration.

### A.3.4 40004 Analog Cal at 0% [Read & Write]

Register: 40004, Address 0x0003 (3).  
 Function code: 0x10 – Write Multiple registers,

0x06 – Write Single register, or  
0x03 – Read Holding registers.

Description: This is a register is used to initiate a calibration of the analog to digital circuit in the system. A write of a '1' will cause the system to store the value at the analog input. This action should be performed with a calibrated 1V or 4mA present at the analog input. If this is not performed the system uses defaults. Values outside the range 0-1 will return an exception code.

### A.3.5 40005 Analog Cal at 100% [Read & Write]

Register: 40005, Address 0x0004 (4).  
Function code: 0x10 – Write Multiple registers,  
0x06 – Write Single register, or  
0x03 – Read Holding registers.

Description: This is a register is used to initiate a calibration of the analog to digital circuit in the system. A write of a '1' will cause the system to store the value at the analog input. This action should be performed with a calibrated 5V or 20mA present at the analog input. If this is not performed the system uses defaults. Values outside the range 0-1 will return an exception code.

### A.3.6 40004-40008 Reserved [Read Only]

Register: 40004-40008 Address 0x0003 (3) - 0x0007 (7).  
Function code: 0x03 – Read Holding registers.  
Description: Not used – reads will return a value of 0.

### A.3.7 40009 Test Register [Read Only]

Register: 40009, Address 0x0008 (8).  
Function code: 0x03 – Read Holding registers.  
Description: A test register – can be used to confirm communications. Holds a power up default of 45964 (0xB38C Hex).

### A.3.8 40010 Actual Position [Read Only]

Register: 40010, Address 0x0009 (9).  
Function code: 0x03 – Read Holding registers.  
Description: This is a value between 0 and 100% that indicates the physical position of a calibrated valve system. If the valve is un-calibrated (indicated if the Diagnostics flags register has a cleared calibration informational flag), then this register will read 0.

### A.3.9 40011 Actual Demand [Read Only]

Register: 40011, Address 0x000A (10).  
Function code: 0x03 – Read Holding registers.  
Description: This is a value between 0 and 100% that indicates the demand to the position control loop from the active control source.

### A.3.10 40012 Diagnostic Flags [Read Only]

Register: 40012, Address 0x000B (11).  
Function code: 0x03 – Read Holding registers.  
Description: This is a set of 16 bit flags that indicate the state of the system. The lower order byte contains flags that cause the system to go to a fault state – actuation of the valve will not be possible



until the cause of the fault condition has been removed and the fault condition reset by writing a reset request to register 40001. The upper order byte contains flags used to indicate the operational status of the valve actuator. See table 5 - Fault Register for details.

### A.3.11 40013-40014 Number of Open/Close Cycles [Read Only]

Register: 40013-40014, Address 0x000C (12) – 0x000D (13).  
Function code: 0x03 – Read Holding registers.  
Description: This is a pair of registers that hold a 32bit number indicating the number of actuations of the valve. A cycle of moving the valve from closed to open and back closed will count as 2 cycles. The register needs to be read using a single read function command to ensure coherency of the data in the two registers.

### A.3.12 40015-40016 Hours/Minutes Running [Read Only]

Register: 40015-40016, Address 0x000E (14) – 0x000F (15).  
Function code: 0x03 – Read Holding registers.  
Description: This is a pair of registers that hold a 32bit number indicating the number of hours the valve has been powered. The register needs to be read using a single read function command to ensure coherency of the data in the two registers. If version 4.13 firmware is installed, hours are displayed. If version 4.21 firmware is installed, minutes are displayed.

### A.3.13 40017-40018 Hours/Minutes Open [Read Only]

Register: 40017-40018, Address 0x0010 (16) – 0x0011 (17).  
Function code: 0x03 – Read Holding registers.  
Description: This is a pair of registers that hold a 32bit number indicating the number of hours the valve has been in the open (100%) position. The register needs to be read using a single read function command to ensure coherency of the data in the two registers. If version 4.13 firmware is installed, hours are displayed. If version 4.21 firmware is installed, minutes are displayed.

### A.3.14 40019-40020 Hours/Minutes Closed [Read Only]

Register: 40019-40020, Address 0x0012 (18) – 0x0013 (19).  
Function code: 0x03 – Read Holding registers.  
Description: This is a pair of registers that hold a 32bit number indicating the number of hours the valve has been in the closed (0%) position. The register needs to be read using a single read function command to ensure coherency of the data in the two registers. If version 4.13 firmware is installed, hours are displayed. If version 4.21 firmware is installed, minutes are displayed.

### A.3.15 40021-40022 Number of Power up cycles [Read Only]

Register: 40021-40022, Address 0x0014 (20) – 0x0015 (21).  
Function code: 0x03 – Read Holding registers.  
Description: This is a pair of registers that hold a 32bit number of times the system has been successfully powered up. The register needs to be read using a single read function command to ensure coherency of the data in the two registers.

### A.3.16 40023-40024 Serial Number [Read Only]

Register: 40023-40024, Address 0x0016-0x0017 (22-23).  
Function code: 0x03 – Read Holding registers.

**Description:** This is a pair of registers that hold a 32 bit number that can be used to hold a unique serial number. The register needs to be read using a single read Modbus function transaction command to ensure coherency of the data in the two registers.

### A.3.17 40025 Analog I/P value [Read Only]

**Register:** 40025, Address 0x0018 (24).  
**Function code:** 0x03 – Read Holding registers.  
**Description:** This is a register that holds a 16 bit scaled representation of the analog input. It is scaled according to input i.e. 0-200 for 0-20.0mA and 0-50 for 1-5 V.

### A.3.18 40026 Firmware Project Code [Read Only]

**Register:** 40026, Address 0x0019 (25).  
**Function code:** 0x03 – Read Holding registers.  
**Description:** This is a register that holds the SRD project code (SRD422) – 422. This is the code used in version control of SRD documents and source code.

### A.3.19 40027 Firmware Document Reference [Read Only]

**Register:** 40027, Address 0x001A (26).  
**Function code:** 0x03 – Read Holding registers.  
**Description:** This is a register that holds the SRD document code (SRD422-5007) – 5007. This code along with the project code is used in version control of SRD documents and source code.

### A.3.20 40028 Firmware Version [Read Only]

**Register:** 40028, Address 0x001B (27).  
**Function code:** 0x03 – Read Holding registers.  
**Description:** This is a register that holds the hex encoded equivalent of a four digit decimal version number of the firmware, the high order 8bits encode the whole number of the version and the low order 8 bits the fraction, e.g. v1.16 would be encoded 0x0110, v2.66 would be 0x0242. Together with the data from registers 40026- 40028 it is possible to determine the unique identity of the code being run in the processor.

### A.3.21 40029 Diagnostic Flags [Read Only]

**Register:** 40029, Address 0x001C (28).  
**Function code:** 0x03 – Read Holding registers.  
**Description:** This is a set of 16 bit flags that show the accumulation of fault flags that have occurred – as faults are self resetting. The register is stored in non-volatile memory. The mapping is the same as the diagnostic register at 40012. See table 5 - Fault Register for guide to values.

### A.3.22 40030-40031 Reserved [Read Only]

**Register:** 40030-40031, Address 0x001D-0x001E (29-30).  
**Function code:** 0x03 – Read Holding registers.  
**Description:** Not used – reads will return a value of 0.

### A.3.23 40032 Valve Type [Read & Write]

Register: 40032, Address 0x001F (31).  
Function code: 0x10 – Write Multiple registers,  
0x06 – Write Single register, or  
0x03 – Read Holding registers.  
Description: This is a register that holds an enumeration of the three types of valve. This is used to set up several internal variables and constants. Writes outside of the legal range 0-2 will be rejected with an exception code.

### A.3.24 40033 Control Type [Read Only]

Register: 40033, Address 0x0020 (32).  
Function code: 0x03 – Read Holding registers.  
Description: This is a register that holds an enumeration of the control type – either 0 for On/Off, or 1 for proportional control.

### A.3.25 40034 Control Source [Read & Write]

Register: 40034, Address 0x0021 (33).  
Function code: 0x10 – Write Multiple registers,  
0x06 – Write Single register, or  
0x03 – Read Holding registers.  
Description: This is a register that holds an enumeration of the control source – either 0 for Modbus RTU control, or 1 for signals local to the system – decided by the contents of register 40032. Note that if the Modbus serial link is not the active mode then the faults associated with serial communications will be disabled, although serial communications for such activities as test and debug monitoring of the analog input will all still function. Writes outside of the legal range 0-1 will be rejected with an exception code.

### A.3.26 40035 Loss of Control Default Position [Read & Write]

Register: 40035, Address 0x0022 (34).  
Function code: 0x10 – Write Multiple registers,  
0x06 – Write Single register, or  
0x03 – Read Holding registers.  
Description: This is a register that holds a position demand 0-100% that will be applied to the position control loop if the active control source is determined to be corrupt or out of normal operating specification, this applies to modbus communications messages being absent or the analog input being un-calibrated or below 3mA/0.75V(open control loop). Writes outside of the legal range 0-100 will be rejected with an exception code.

### A.3.27 40036 Deadband [Read & Write]

Register: 40036, Address 0x0023 (35).  
Function code: 0x10 – Write Multiple registers,  
0x06 – Write Single register, or  
0x03 – Read Holding registers.  
Description: This is a register that holds an integer value of percentage hysteresis used to discriminate against noise entering the control system from the selected control source, this can take a value of 0-100%, e.g. a value of 100 would make the system only respond to 0 or 100% demands. Writes outside of the legal range 0-100 will be rejected with an exception code.

### A.3.28 40037 Low travel Cutoff [Read & Write]

Register: 40037, Address 0x0024 (36).  
Function code: 0x10 – Write Multiple registers,  
0x06 – Write Single register, or  
0x03 – Read Holding registers.  
Description: This is a register that holds an integer value of percentage used as a clamp – any position demand less than this value will be clamped to zero before being passed to the position control system.

### A.3.29 40038 Communications Timeout [Read & Write]

Register: 40038, Address 0x0025 (37).  
Function code: 0x10 – Write Multiple registers,  
0x06 – Write Single register, or  
0x03 – Read Holding registers.  
Description: This is a register that holds a value 0-65535 that is the number of seconds for a timeout before the modbus serial communications channel is determined to be uncommunicative (0 - ~ 18Hrs). A valid addressed message must be received by the system within this time limit if the active control source is Modbus RTU communications. If the time without communications is exceeded the system will fault and the valve commanded to the default loss of communications position. A value of 0 can be used to disable this feature. If communications is resumed then the flag will be cleared and the valve will take the refreshed position as a demand. The use of this register is shown in table 5 - Fault Register.

### A.3.30 40039 Communications Address [Read & Write]

Register: 40039, Address 0x0026 (38).  
Function code: 0x10 – Write Multiple registers,  
0x06 – Write Single register, or  
0x03 – Read Holding registers.  
Description: This is a register that holds a value 1-247 that is the Modbus address used by the system on power up. Values outside the range 1-247 will return an exception code

### A.3.31 40040 Communications Baudrate [Read & Write]

Register: 40040, Address 0x0027 (39).  
Function code: 0x10 – Write Multiple registers,  
0x06 – Write Single register, or  
0x03 – Read Holding registers.  
Description: This is a register that holds a value 4-6 that is an enumeration of the baudrate used by the system on power up.

### A.3.32 40041 Parity [Read & Write]

Register: 40041, Address 0x0028 (40).  
Function code: 0x10 – Write Multiple registers,  
0x06 – Write Single register, or  
0x03 – Read Holding registers.  
Description: This is a register that holds an enumeration of the parity type used by the Modbus serial interface – either 0 for Odd, or 1 for Even in version 4.13 firmware (version 4.21 firmware defines 0=Odd, 1=Even, 2=None). Writes outside of the legal range will be rejected with an exception code.

### A.3.33 40042 Reset Statistics [Read & Write]

Register: 40042, Address 0x0029 (41).

Function code: 0x10 – Write Multiple registers,  
0x06 – Write Single register, or  
0x03 – Read Holding registers.

Description: This is a register used to reset the non volatile system statistics (such as number of hours run). Writing a value of 1 to these registers will reset the values that accessed in registers 40013-40022 to 0.

### A.3.34 40043 Analog Input Mode [Read & Write]

Register: 40043, Address 0x002A (42).

Function code: 0x10 – Write Multiple registers,  
0x06 – Write Single register, or  
0x03 – Read Holding registers.

Description: This is a register that holds an enumeration 0-1 that sets the mode of operation for on/off and proportional control. When in proportional mode (40033 = 1), a value of 0 sets the unit for using a 1-5V voltage input. 1 sets up the unit for using a 4-20 mA current command input. The scaling of the different modes is reflected in the scaling of the value reported in register at 40023 – ‘Analog I/P value’. When in on/off mode (40033 = 0), a value of 0 sets the unit for using both digital inputs, optimized for using the L2e level controller. 1 sets up the unit for using a single digital input. See Operation for further details.

## A.4 Example Modbus Protocol Transactions

### A.4.1 Write to Position Demand Register (40002/0x0001/1)

Write of a position demand value of 100% to device at address 1 on the Modbus network – 8 characters.

FIELD	SLAVE ADDRESS	FUNCTION CODE	REGISTER ADDRESS HI	REGISTER ADDRESS LO	REGISTER DATA HI	REGISTER DATA LO	CRC LO	CRC HI
Index	0	1	2	3	4	5	6	7
Hex (Dec)	0x01 (1)	0x06 (6)	0x00 (0)	0x01 (1)	0x00 (0)	0x64 (100)	0xD9 (217)	0xE1 (225)

Normal response, 8 characters:

FIELD	SLAVE ADDRESS	FUNCTION CODE	REGISTER ADDRESS HI	REGISTER ADDRESS LO	REGISTER DATA HI	REGISTER DATA LO	CRC LO	CRC HI
Index	0	1	2	3	4	5	6	7
Hex (Dec)	0x01 (1)	0x06 (6)	0x00 (0)	0x01 (1)	0x00 (0)	0x64 (100)	0xD9 (217)	0xE1 (225)

Write of a position demand value of 101% to device at address 1 on the Modbus network, note that this value (101% is outside the legal range of values permitted to be written to this address, so an exception frame is generated – 8 characters.

FIELD	SLAVE ADDRESS	FUNCTION CODE	REGISTER ADDRESS HI	REGISTER ADDRESS LO	REGISTER DATA HI	REGISTER DATA LO	CRC LO	CRC HI
Index	0	1	2	3	4	5	6	7
Hex (Dec)	0x01 (1)	0x06 (6)	0x00 (0)	0x01 (1)	0x00 (0)	0x65 (101)	0x18 (24)	0x21 (33)

Exception response, write not OK – slave device failure (Code 4), error code is function code with 0x80 added, 5 characters returned:-

FIELD	SLAVE ADDRESS	ERROR CODE	EXCEPTION CODE	CRC LO	CRC HI
Index	0	1	2	3	4
Hex (Dec)	0x01 (1)	0x06 (6)	0x00 (0)	0x18 (24)	0x21 (33)

#### A.4.2 Read of Actual Position (40010/0x0009/9)

Read of actual position from device at address 1 on the Modbus network using read holding register function – 8 characters.

FIELD	SLAVE ADDRESS	FUNCTION CODE	REGISTER ADDRESS HI	REGISTER ADDRESS LO	QUANTITY OF REGS HI	QUANTITY OF REGS LO	CRC LO	CRC HI
Index	0	1	2	3	4	5	6	7
Hex (Dec)	0x01 (1)	0x03 (3)	0x00 (0)	0x09 (9)	0x00 (0)	0x01 (1)	0x54 (84)	0x08 (8)

Normal response (returning a value of 0%), 7 characters returned:-

FIELD	SLAVE ADDRESS	FUNCTION CODE	BYTE COUNT	REGISTER ADDRESS HI	REGISTER ADDRESS LO	CRC LO	CRC HI
Index	0	1	2	4	5	6	7
Hex (Dec)	0x01 (1)	0x03 (3)	0x02 (2)	0x00 (0)	0x00 (0)	0xB8 (184)	0x44 (68)

**Neither Emerson, Emerson Process Management, nor any of their affiliated entities assumes responsibility for the selection, use or maintenance of any product. Responsibility for proper selection, use, and maintenance of any product remains solely with the purchaser and end user.**

Fisher and easy-Drive are marks owned by one of the companies in the Emerson Process Management business unit of Emerson Electric Co. Emerson Process Management, Emerson, and the Emerson logo are trademarks and service marks of Emerson Electric Co. All other marks are the property of their respective owners.

The contents of this publication are presented for informational purposes only, and while every effort has been made to ensure their accuracy, they are not to be construed as warranties or guarantees, express or implied, regarding the products or services described herein or their use or applicability. All sales are governed by our terms and conditions, which are available upon request. We reserve the right to modify or improve the designs or specifications of such products at any time without notice.

#### Emerson Process Management

Marshalltown, Iowa 50158 USA  
 Sorocaba, 18087 Brazil  
 Chatham, Kent ME4 4QZ UK  
 Dubai, United Arab Emirates  
 Singapore 128461 Singapore

[www.Fisher.com](http://www.Fisher.com)

