

1301 Series High-Pressure Regulators



Figure 1. Type 1301F Regulator

Features

- **Durable Stainless Steel Diaphragm**—For high-outlet pressure applications.
- **Spare Valve Disk Provided**—Extra valve disk through a reversible disk holder assembly.
- **Versatility**—Can control a variety of media including air, gas, water, and other liquids.
- **ANSI Class VI Shutoff**—Soft-seat valve plug disks ensure tight shutoff.
- **Sour Gas Service Capability**—Optional materials are available for applications handling sour gases. These constructions comply with the recommendations of NACE International Standards MR0175 and MR0103.

Introduction

The proven reliability and accurate regulation of the 1301 Series regulators (see Figure 1) make them ideal for numerous high-pressure drop applications. They are direct-operated, high-pressure regulators designed for inlet pressures up to 6000 psig / 414 bar. The Type 1301F can handle outlet pressures from 10 to 225 psig / 0.69 to 15.5 bar in three ranges and the Type 1301G can handle outlet pressures from 200 to 500 psig / 13.8 to 34.5 bar in one range.

These multi-purpose regulators can be used as pilot supply or pressure-loaded regulators where high-pressure operating medium must be reduced for use by gas regulator pilots or pressure-loaded regulators. Their rugged design offers versatility for a wide variety of applications including air, gas, water, and other liquids. An optional spring case with a tapped vent and adjusting screw closing cap is available that enables the Type 1301F to be used as a pressure-loaded regulator.

Bulletin 71.1:1301

Specifications

Available Configurations

Type 1301F: Direct-operated, high-pressure reducing regulator for inlet pressures to 6000 psig / 414 bar and outlet pressure ranges from 10 to 225 psig / 0.69 to 15.5 bar in three ranges

Type 1301G: Direct-operated, high-pressure reducing regulator for inlet pressures to 6000 psig / 414 bar and an outlet pressure range of 200 to 500 psig / 13.8 to 34.5 bar

Body Size and End Connection Style

1/4 NPT (one inlet and two outlet connections);
CL300 RF, CL600 RF, and CL1500 RF; or
PN 25 RF (all flanges are 125 RMS)

Maximum Inlet Pressure⁽¹⁾

Brass Body:

Air and Gas:

6000 psig / 414 bar at or below 200°F / 93°C and
1000 psig / 69.0 bar above 200°F / 93°C

Liquid:

Polytetrafluoroethylene (PTFE) Disk:

1000 psig / 69.0 bar

Nylon (PA) Disk:

Water: 1000 psig / 69.0 bar

Other Liquids: 2000 psig / 138 bar

Stainless Body:

Air and Gas: 6000 psig / 414 bar

Liquid:

Polytetrafluoroethylene (PTFE) Disk:

1000 psig / 69.0 bar

Nylon (PA) Disk:

Water: 1000 psig / 69.0 bar

Other Liquids: 2000 psig / 138 bar

Maximum Emergency Outlet Pressure⁽¹⁾

Type 1301F: 250 psig / 17.2 bar

Type 1301G: 550 psig / 37.9 bar

Outlet Pressure Ranges

See Table 1

Pressure Registration

Internal

Recovery Coefficient

K_m: 0.72

Flow Capacities

Air: See Tables 2, 3, and 4

Water: See Tables 5 and 6

C_v Coefficients at 20% Droop

Type 1301F: See Table 7

Type 1301G: See Table 8

Wide-Open Flow Coefficients for Relief Valve Sizing

C_g: 5.0

C_v: 0.13

C_t: 38.5

IEC Sizing Coefficients

X_T: 0.938

F_D: 0.50

F_L: 0.85

Orifice Size

5/64-inch / 2.0 mm

Temperature Capabilities⁽¹⁾

Nylon (PA) Valve Disk and Neoprene (CR)

Gaskets: -20 to 180°F / -29 to 82°C

PTFE Valve Disk and Fluorocarbon (FKM)

Gaskets: -20 to 400°F / -29 to 204°C⁽²⁾

PTFE Valve Disk and Ethylenepropylene (EPDM)

Gaskets: -40 to 300°F / -40 to 149°C

Low Temperature Service

Service to -65°F / -54°C is available with low temperature bolting and special low temperature Nitrile (NBR) O-rings to replace the gaskets.

Service to -80°F / -62°C is available with low temperature bolting and special low temperature Fluorosilicone (FVQM) O-rings to replace the gaskets.

Spring Case Vents

Type 1301F Brass Spring Case:

Four 5/32-inch / 4.0 mm holes

Type 1301F Stainless Steel Spring Case:

One 1/4 NPT connection

Type 1301G:

One 1/8 NPT connection with screen

Options

- Pipe plug in second outlet
- Handwheel adjusting screw (Type 1301F only)
- Panel mounting spring case with T-handle adjusting screw (Type 1301G only)
- Bracket for mounting regulator on yoke of control valve actuator
- NACE construction
- Stainless steel construction

Approximate Weight

8 pounds / 3.6 kg

1. The pressure/temperature limits in this Bulletin and any applicable standard or code limitation should not be exceeded.

2. Fluorocarbon (FKM) is limited to 180°F / 82°C hot water.

- continued -

Specifications (continued)

Construction Materials

Standard Construction

Body and Spring Case: Forged brass or CF8M Stainless steel
Bottom Cap: Brass, 304 Stainless steel, or 316 Stainless steel
Orifice: 303 Stainless steel
Valve Disks and Holder: Nylon (PA) and Zinc-plated brass, PTFE and Zinc-plated brass, Nylon (PA) and 303 Stainless steel, or PTFE and 303 Stainless steel
Orifice Yoke: Brass or 316 Stainless steel
Valve Disk Collar: 304 Stainless steel
Elastomers: Neoprene (CR), Fluorocarbon (FKM), or Ethylenepropylene (EPDM)
Regulator Spring: Zinc-plated steel
Valve Spring: 302 Stainless steel
Diaphragm Plate: Zinc-plated steel
Adjusting Screw and Bolting: Double Zinc-plated steel with zinc dichromate overlay
Upper Spring Seat: Zinc-plated steel
Diaphragm: 302 Stainless steel

Construction Materials (continued)

NACE Construction

Body and Bottom Cap: CF8M Stainless steel
Spring Case: CF8M Stainless steel
Orifice: 316 Stainless steel
Valve Disks and Holder: PTFE and 316 Stainless steel
Orifice Yoke: 316 Stainless steel
Valve Disk Collar: 316 Stainless steel
Gaskets: Fluorocarbon (FKM)
Bottom Cap O-ring: Fluorocarbon (FKM)
Regulator Spring: Zinc-plated steel
Valve Spring: Inconel® X750
Diaphragm Plate: Zinc-plated steel
Adjusting Screw and Bolting: Double Zinc-plated steel with zinc dichromate overlay
Upper Spring Seat: Zinc-plated steel
Diaphragm: K500 Monel®

Inconel® and Monel® are marks owned by Special Metals Corporation.

Table 1. Outlet Pressure Ranges

TYPE	OUTLET PRESSURE RANGES ⁽¹⁾		SPRING PART NUMBER	SPRING COLOR CODE	SPRING WIRE DIAMETER		SPRING FREE LENGTH	
	psig	bar			Inch	mm	Inch	mm
1301F	10 to 75	0.69 to 5.2	1D387227022	Blue	0.200	5.08	1.69	42.9
	50 to 150	3.4 to 10.3	1B788527022	Silver	0.225	5.72		
	100 to 225	6.9 to 15.5	1D465127142	Red	0.243	6.17		
1301G	200 to 500	13.8 to 34.5	1K156027142	Silver	0.331	8.41	1.88	47.8

1. All springs can be backed off to 0 psig / 0 bar.

Principle of Operation

The 1301 Series regulators are direct-operated. Downstream pressure is registered internally through the body to the underside of the diaphragm. When downstream pressure is at or above set pressure, the disk is held against the orifice and there is no flow through the regulator. When demand increases, downstream pressure decreases slightly allowing the regulator spring to extend, moving the yoke and disk assembly down and away from the orifice. This allows flow through the body to the downstream system. As the downstream pressure reach its setting, it started to overcome the spring force which is sensed by the diaphragm, moving the yoke and disk assembly up and near its orifice, restricting the flow across the regulator.

Installation

The 1301 Series regulators may be installed in any position. Spring case vents must be protected against the entrance of rain, snow, debris, or any other foreign material that might plug the vent openings. The inlet connection is marked

“In” and the three outlet connections are marked “Out”. If a pressure gauge is not installed in one outlet connection, plug the unused connection. See Figure 3 for dimensions.

Overpressure Protection

The 1301 Series regulators have outlet pressure ratings lower than the inlet pressure ratings. Complete downstream overpressure protection is needed if the actual inlet pressure exceeds the outlet pressure rating.

Overpressuring any portion of a regulator or associated equipment may cause leakage, parts damage, or personal injury due to bursting of pressure-containing parts or explosion of accumulated gas. Regulator operation within ratings does not preclude the possibility of damage from external sources or from debris in the pipeline. A regulator should be inspected for damage periodically and after any overpressure condition.

Refer to the relief sizing coefficients in the Specifications and the Capacity Information section to determine the required relief valve capacity.

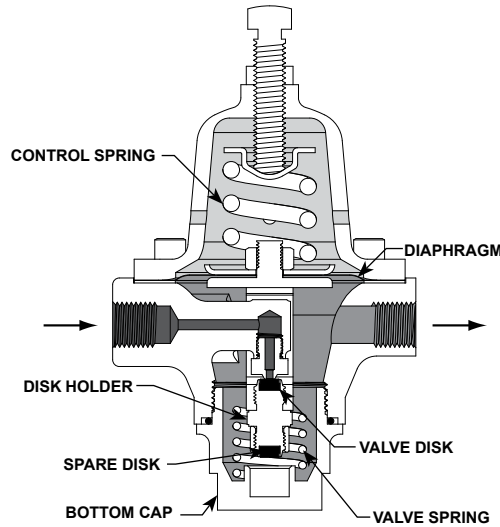

M1015

- INLET PRESSURE
- OUTLET PRESSURE
- ATMOSPHERIC PRESSURE

Figure 2. Type 1301F Operational Schematic

Capacity Information

Air Capacities

Tables 2 and 3 give regulating capacities at selected pressures and outlet pressure flows in SCFH (at 60°F and 14.7 psia) and Nm³/h (at 0°C and 1.01325 bar) of air. To determine the equivalent capacities for other gases, multiply the table capacities by the following appropriate conversion factors: 1.29 for 0.6 specific gravity natural gas, 0.808 for propane, 0.707 for butane, or 1.018 for nitrogen. For gases of other specific gravities, divide by the square root of the appropriate specific gravity.

To determine wide-open flow capacity for relief valve sizing, use one of the following equations:

For Critical Pressure Drops

Use this equation for critical pressure drops (absolute outlet pressure equal to one-half or less than one-half the absolute inlet pressure).

$$Q = P_{1(\text{abs})} C_g$$

where,

- Q = gas flow rate, SCFH
- C_g = gas sizing coefficient
- P₁ = absolute inlet pressure, psia

For Non-Critical Pressure Drops

Use this equation for pressure drops lower than critical (absolute outlet pressure greater than one-half of absolute inlet pressure).

$$Q = \sqrt{\frac{520}{GT}} C_g P_1 \text{SIN} \left[\frac{3417}{C_1} \sqrt{\frac{\Delta P}{P_1}} \right] \text{DEG}$$

where,

- Q = gas flow rate, SCFH
- G = specific gravity of the gas
- T = absolute temperature of gas at inlet, °Rankine
- C_g = gas sizing coefficient
- P₁ = absolute inlet pressure, psia
- C₁ = flow coefficient
- ΔP = pressure drop across the regulator, psi

Then, if capacity is desired in normal cubic meters per hour at 0°C and 1.01325 bar, multiply SCFH by 0.0268.

Liquid Capacities

Tables 5 and 6 give regulating capacities in U.S. gallons per minute and liters per minute of water.

To determine regulating capacities at pressure settings not given in Tables 5 and 6, or to determine wide-open capacities for relief sizing at any inlet pressure, use the following equation.

$$Q = C_v \sqrt{\frac{\Delta P}{G}}$$

where,

- Q = liquid flow rate, GPM
- ΔP = pressure drop across the regulator, psi
- C_v = regulating or wide-open flow coefficient
- G = specific gravity of the liquid

Table 2. Type 1301F Regulating Capacities — Air with 100 to 750 psig / 6.9 to 51.7 bar Inlet Pressure

OUTLET PRESSURE RANGE, SPRING PART NUMBER, AND COLOR	OUTLET PRESSURE SETTING		CAPACITIES IN SCFH / Nm ³ /h OF AIR															
			Inlet Pressure, psig / bar															
			100 / 6.9				250 / 17.2				500 / 34.5				750 / 51.7			
			10% Droop		20% Droop		10% Droop		20% Droop		10% Droop		20% Droop		10% Droop		20% Droop	
			psig	bar	SCFH	Nm ³ /h	SCFH	Nm ³ /h	SCFH	Nm ³ /h	SCFH	Nm ³ /h	SCFH	Nm ³ /h	SCFH	Nm ³ /h	SCFH	Nm ³ /h
10 to 75 psig / 0.69 to 5.2 bar 1D387227022, Blue	25	1.7	190	5.1	290	7.8	300	8.0	480	12.9	400	10.7	650	17.4	500	13.4	750	20.1
	50	3.4	280	7.5	400	10.7	480	12.9	800	21.4	720	19.3	1000	26.8	840	22.5	1200	32.2
	75	5.2	250	6.7	400	10.7	600	16.1	900	24.1	900	24.1	1400	37.5	1000	26.8	1600	42.9
50 to 150 psig / 3.4 to 10.3 bar 1B788527022, Silver	75	5.2	200	5.4	350	9.4	500	13.4	800	21.4	800	21.4	1300	34.8	950	25.5	1500	40.2
	150	10.3	----	----	----	----	750	20.1	1000	26.8	1100	29.5	1800	48.2	1450	38.9	2300	61.6
100 to 225 psig / 6.9 to 15.5 bar 1D465127142, Red	150	10.3	----	----	----	----	650	17.4	900	24.1	1000	26.8	1700	45.6	1350	36.2	2200	59.0
	225	15.5	----	----	----	----	500	13.4	800	21.4	1400	37.5	2100	56.3	1900	50.9	2900	77.7

Table 3. Type 1301F Regulating Capacities — Air with 1000 to 2000 psig / 69.0 to 138 bar Inlet Pressure

OUTLET PRESSURE RANGE, SPRING PART NUMBER, AND COLOR	OUTLET PRESSURE SETTING		CAPACITIES IN SCFH / Nm ³ /h OF AIR											
			Inlet Pressure, psig / bar											
			1000 / 69.0				1500 / 103				2000 / 138			
			10% Droop		20% Droop		10% Droop		20% Droop		10% Droop		20% Droop	
			psig	bar	SCFH	Nm ³ /h	SCFH	Nm ³ /h	SCFH	Nm ³ /h	SCFH	Nm ³ /h	SCFH	Nm ³ /h
10 to 75 psig / 0.69 to 5.2 bar 1D387227022, Blue	25	1.7	520	13.9	770	20.6	540	14.5	800	21.4	560	15.0	820	22.0
	50	3.4	900	24.1	1300	34.8	950	25.5	1400	37.5	1000	26.8	1500	40.2
	75	5.2	1100	29.5	1700	45.6	1200	32.2	1800	48.2	1300	34.8	1900	50.9
50 to 150 psig / 3.4 to 10.3 bar 1B788527022, Silver	75	5.2	1000	26.8	1600	42.9	1100	29.5	1700	45.6	1200	32.2	1800	48.2
	150	10.3	1600	42.9	2600	69.7	1700	45.6	2800	75.0	1800	48.2	3000	80.4
100 to 225 psig / 6.9 to 15.5 bar 1D465127142, Red	150	10.3	1500	40.2	2250	60.3	1650	44.2	2750	73.7	1800	48.2	3000	80.4
	225	15.5	2400	64.3	3500	93.8	2700	72.4	4000	107	3000	80.4	4500	121

Table 4. Type 1301G Regulating Capacities — Air

OUTLET PRESSURE RANGE, SPRING PART NUMBER, AND COLOR	OUTLET PRESSURE SETTING		OFFSET		CAPACITIES IN SCFH / Nm ³ /h OF AIR															
					Inlet Pressure, psig / bar															
					300 / 20.7		500 / 34.5		750 / 51.7		1000 / 69.0		1500 / 103		2000 / 138		2250 / 155			
					10% Droop		20% Droop		10% Droop		20% Droop		10% Droop		20% Droop		10% Droop		20% Droop	
					psig	bar	psig	bar	SCFH	Nm ³ /h	SCFH	Nm ³ /h	SCFH	Nm ³ /h	SCFH	Nm ³ /h	SCFH	Nm ³ /h	SCFH	Nm ³ /h
200 to 500 psig / 13.8 to 34.5 bar 1K156027142, Silver	200	13.8	10	0.69	350	9.4	550	14.7	750	20.1	950	25.5	1100	29.5	1250	33.5	1400	37.5		
			20	1.4	650	17.4	900	24.1	1200	32.2	1500	40.2	1800	48.2	2000	53.6	2100	56.3		
			30	2.1	900	24.1	1350	36.2	1700	45.6	2000	53.6	2300	61.6	2700	72.4	3000	80.4		
			40	2.8	1100	29.5	1650	44.2	2100	56.3	2500	67.0	3000	80.4	3500	93.8	3700	99.2		
	500	34.5	15	1.0	----	----	----	----	800	21.4	1000	26.8	1300	34.8	1500	40.2	1600	42.9		
			25	1.7	----	----	----	----	1400	37.5	1600	42.9	2000	53.6	2600	69.7	2800	75.0		
			50	3.4	----	----	----	----	2200	59.0	2800	75.0	3300	88.4	4000	107	4500	121		

Table 5. Type 1301F Regulating Capacities — Water⁽¹⁾

OUTLET PRESSURE RANGE, SPRING PART NUMBER, AND COLOR	OUTLET PRESSURE SETTING		CAPACITIES IN GALLONS / liters PER MINUTE OF WATER BASED ON 20% DROOP											
			Inlet Pressure, psig / bar											
			100 / 6.9		250 / 17.2		500 / 34.5		750 / 51.7		1000 / 69.0 ⁽¹⁾			
			10% Droop		20% Droop		10% Droop		20% Droop		10% Droop		20% Droop	
			psig	bar	Gallons	Liters	Gallons	Liters	Gallons	Liters	Gallons	Liters	Gallons	Liters
10 to 75 psig / 0.69 to 5.2 bar 1D387227022, Blue	25	1.7	0.50	2.0	0.73	2.8	0.94	3.6	1.09	4.1	1.16	4.4		
	50	3.4	0.50	2.0	0.83	3.1	1.12	4.2	1.32	5.0	1.43	5.4		
	75	5.2	0.46	1.7	0.91	3.4	1.28	4.8	1.52	5.7	1.69	6.4		
50 to 150 psig / 3.4 to 10.3 bar 1B788527022, Silver	75	5.2	0.43	1.6	0.88	3.3	1.24	4.7	1.49	5.6	1.65	6.2		
	150	10.3	----	----	1.01	3.8	1.64	6.2	2.02	7.6	2.31	8.7		
100 to 225 psig / 6.9 to 15.5 bar 1D4651270142, Red	150	10.3	----	----	0.95	3.6	1.56	5.9	1.96	7.4	2.24	8.5		
	225	15.5	----	----	0.84	3.2	1.73	6.5	2.27	8.6	2.68	10.1		

1. Inlet pressure greater than 1000 psig / 69.0 bar is not recommended for water service.

Bulletin 71.1:1301

Table 6. Type 1301G Regulating Capacities — Water⁽¹⁾

OUTLET PRESSURE RANGE, SPRING PART NUMBER, AND COLOR	OUTLET PRESSURE SETTING		CAPACITIES IN GALLONS / liters PER MINUTE OF WATER BASED ON 20% DROOP							
			Inlet Pressure, psig / bar							
			300 / 20.7		500 / 34.5		750 / 51.7		1000 / 69.0 ⁽¹⁾	
	psig	bar	Gallons	Liters	Gallons	Liters	Gallons	Liters	Gallons	Liters
200 to 500 psig / 13.8 to 34.5 bar 1K156027142, Silver	200	13.8	1.12	4.2	1.73	6.5	2.24	8.5	2.64	10.0
	500	34.5	-----	-----	-----	-----	1.99	7.5	2.58	9.8

1. Inlet pressure greater than 1000 psig / 69.0 bar is not recommended for water service.

Table 7. Type 1301F C_v Coefficients⁽¹⁾ — Incompressible Fluid

OUTLET PRESSURE RANGE, SPRING PART NUMBER, AND COLOR	OUTLET PRESSURE SETTING		TYPE 1301F C _v COEFFICIENTS BASED ON 20% DROOP						
			Inlet Pressure, psig / bar						
	psig	bar	100 / 6.9	250 / 17.2	500 / 34.5	750 / 51.7	1000 / 69.0	1500 / 103 ⁽¹⁾	2000 / 138 ⁽¹⁾
10 to 75 psig / 0.69 to 5.2 bar 1D387227022, Blue	25	1.7	0.056	0.048	0.043	0.040	0.037	0.032	0.029
	50	3.4	0.065	0.057	0.052	0.050	0.046	0.041	0.038
	75	5.2	0.073	0.066	0.061	0.058	0.055	0.051	0.049
50 to 150 psig / 3.4 to 10.3 bar 1B788527022, Silver	75	5.2	0.068	0.064	0.059	0.057	0.054	0.050	0.047
	150	10.3	-----	0.089	0.084	0.080	0.078	0.075	0.074
100 to 225 psig / 6.9 to 15.5 bar 1D4651270142, Red	150	10.3	-----	0.083	0.080	0.078	0.076	0.074	0.074
	225	15.5	-----	0.100	0.097	0.095	0.094	0.092	0.091

1. Inlet pressure greater than 1000 psig / 69.0 bar is not recommended for water service.

Table 8. Type 1301G C_v Coefficients⁽¹⁾ — Incompressible Fluid

OUTLET PRESSURE RANGE, SPRING PART NUMBER, AND COLOR	OUTLET PRESSURE SETTING		TYPE 1301G C _v COEFFICIENTS BASED ON 20% DROOP						
			Inlet Pressure, psig / bar						
	psig	bar	300 / 20.7	500 / 34.5	750 / 51.7	1000 / 69.0	1500 / 103 ⁽¹⁾	2000 / 138 ⁽¹⁾	2250 / 155 ⁽¹⁾
200 to 500 psig / 13.8 to 34.5 bar 1K156027142, Silver	200	13.8	0.095	0.094	0.092	0.091	0.089	0.088	0.088
	500	34.5	-----	-----	0.106	0.105	0.104	0.103	0.103

1. Inlet pressure greater than 1000 psig / 69.0 bar is not recommended for water service.

Maximum Allowable Pressure Drop for Liquid

Pressure drops in excess of allowable will result in choked flow and possible cavitation damage. Choked flow is the formation of vapor bubbles in the liquid flowstream causing a condition at the vena contracta which tends to limit flow through the regulator. The vena contracta is the minimum cross-sectional area of the flow stream occurring just downstream of the actual physical restriction. Cavitation and flashing are physical changes in the process fluid. The change is from the liquid state to the vapor state and results from the increase in fluid velocity at or just downstream of the greatest flow restriction, normally the regulator orifice.

To determine the maximum allowable pressure drop for water:

$$\Delta P (\text{allow}) = K_m (P_1)$$

where,

- ΔP = pressure drop across the regulator, psi
- K_m = valve recovery coefficient
- P_1 = absolute inlet pressure, psia

To determine maximum allowable pressure drop for fluids other than water, use other Fisher® sizing methods or contact your local Sales Office for assistance.

Universal NACE Compliance

Optional materials are available for applications handling sour gases. These constructions comply with the recommendations of NACE International sour service standards.

The manufacturing processes and materials used by Emerson Process Management Regulator Technologies, Inc. assure that all products specified for sour gas service comply with the chemical, physical, and metallurgical requirements of NACE MR0175 and/or NACE MR0103. Customers have the responsibility to specify correct materials. Environmental limitations may apply and shall be determined by the user.

Ordering Information

Use the Specifications section on pages 2 and 3 to complete the Ordering Guide on page 8. Specify the desired selection wherever there is a choice to be made. Provide your Sales Office with this information when ordering the regulator.

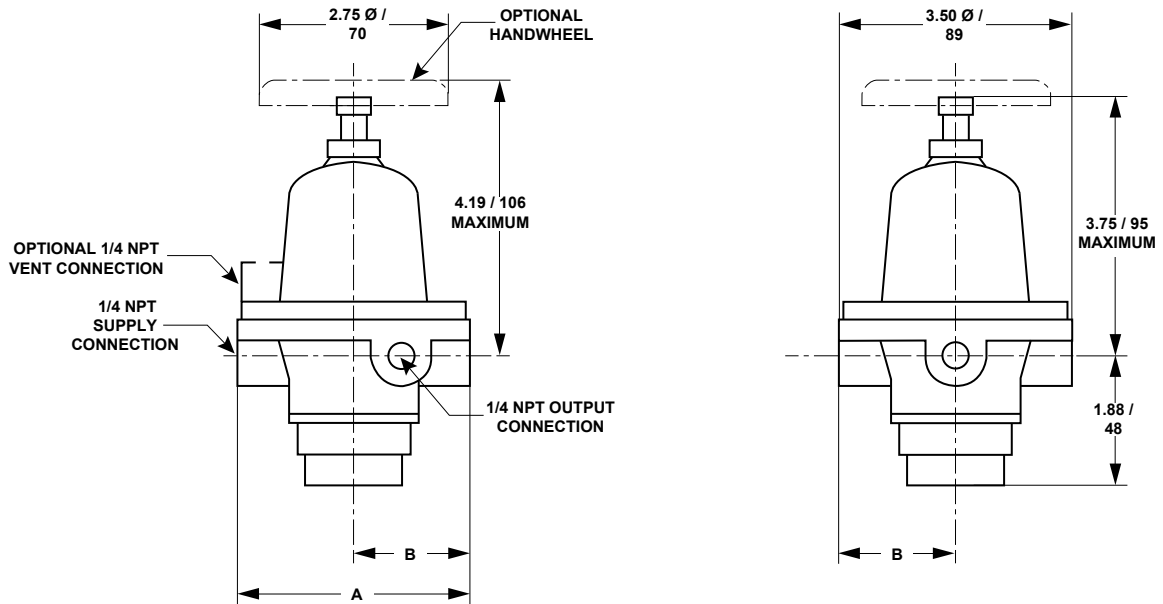

AK2724_H

TYPE 1301F

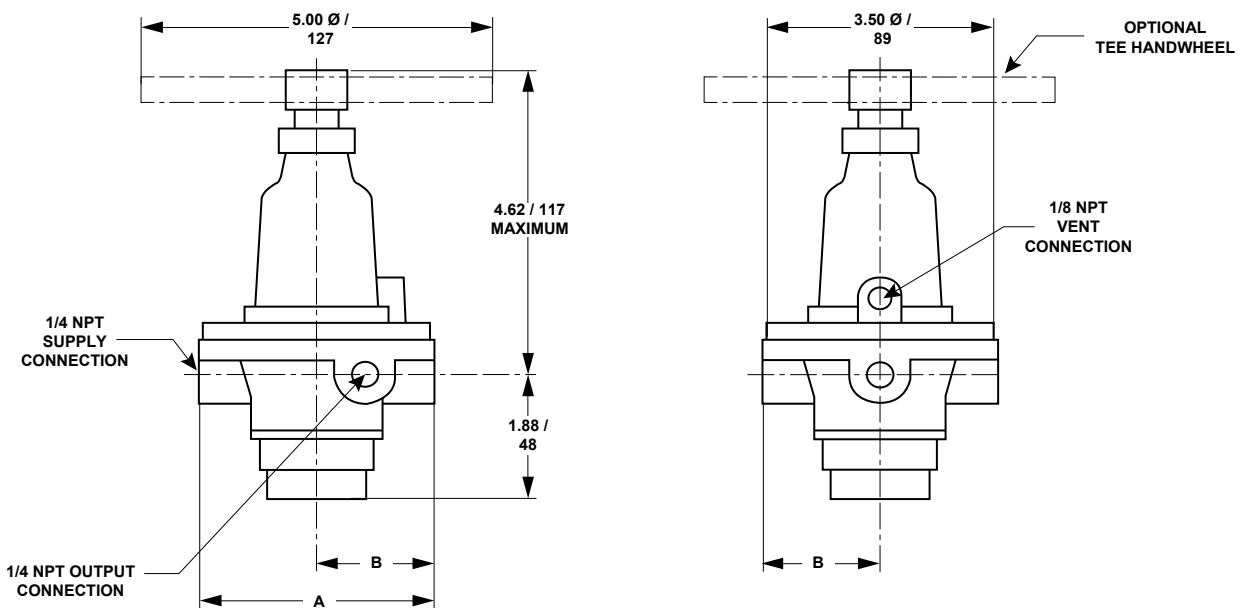

AK2725_F

TYPE 1301G

INCH /
mm

Figure 3. 1301 Series Dimensions

Table 9. 1301 Series Dimensions

TYPE	BODY MATERIAL	DIMENSIONS			
		A		B	
		Inch	mm	Inch	mm
1301F	Brass	3.38	86	1.69	43
	Stainless steel	3.62	92	1.75	44
1301G	Brass	3.38	86	1.69	43
	Stainless steel	3.62	92	1.75	44

Bulletin 71.1:1301

Ordering Guide

Type (Select One)

1301F

- 10 to 75 psig / 0.69 to 5.2 bar***
- 50 to 150 psig / 3.4 to 10.3 bar***
- 100 to 225 psig / 6.9 to 15.5 bar***

1301G

- 200 to 500 psig / 13.8 to 34.5 bar***

Dual Gauge Port Construction (Optional)

- Yes

Body and Spring Case Material (Select One)

- Brass***
- CF8M Stainless steel**

Valve Disk (Select One)

- Nylon (PA)***
- PTFE**

Gaskets (Select One)

- Neoprene (CR)***
- Fluorocarbon (FKM)**
- Ethylenepropylene (EPDM)*
- Fluorosilicone (FVMQ)**

Regulators Quick Order Guide	
***	Standard - Readily Available for Shipment
**	Non-Standard - Allow Additional Time for Shipment
*	Special Order, Constructed from Non-Stocked Parts. Consult your local Sales Office for Availability.
Availability of the product being ordered is determined by the component with the longest shipping time for the requested construction.	

Replacement Parts Kit (Optional)

- Yes, send one replacement parts kit to match this order.

Specification Worksheet

Application:
 Specific Use _____
 Line Size _____
 Fluid Type _____
 Specific Gravity _____
 Temperature _____
 Does the Application Require Overpressure Protection?
 Yes No

Pressure:
 Maximum Inlet Pressure _____
 Minimum Inlet Pressure _____
 Differential Pressure _____
 Set Pressure _____
 Maximum Flow _____

Accuracy Requirements:
 Less Than or Equal To:
 5% 10% 20% 40%

Construction Material Requirements (if known):

Industrial Regulators

Emerson Process Management Regulator Technologies, Inc.

USA - Headquarters
 McKinney, Texas 75070 USA
 Tel: +1 800 558 5853
 Outside U.S. +1 972 548 3574

Asia-Pacific
 Shanghai 201206, China
 Tel: +86 21 2892 9000

Europe
 Bologna 40013, Italy
 Tel: +39 051 419 0611

Middle East and Africa
 Dubai, United Arab Emirates
 Tel: +011 971 4811 8100

Natural Gas Technologies

Emerson Process Management Regulator Technologies, Inc.

USA - Headquarters
 McKinney, Texas 75070 USA
 Tel: +1 800 558 5853
 Outside U.S. +1 972 548 3574

Asia-Pacific
 Singapore 128461, Singapore
 Tel: +65 6770 8337

Europe
 Bologna 40013, Italy
 Tel: +39 051 419 0611
 Chartres 28008, France
 Tel: +33 2 37 33 47 00

Middle East and Africa
 Dubai, United Arab Emirates
 Tel: +011 971 4811 8100

TESCOM

Emerson Process Management Tescom Corporation

USA - Headquarters
 Elk River, Minnesota 55330-2445, USA
 Tels: +1 763 241 3238
 +1 800 447 1250

Europe
 Selmsdorf 23923, Germany
 Tel: +49 38823 31 287

Asia-Pacific
 Shanghai 201206, China
 Tel: +86 21 2892 9499

For further information visit www.fisherregulators.com

The Emerson logo is a trademark and service mark of Emerson Electric Co. All other marks are the property of their prospective owners. Fisher is a mark owned by Fisher Controls International LLC, a business of Emerson Process Management.

The contents of this publication are presented for informational purposes only, and while every effort has been made to ensure their accuracy, they are not to be construed as warranties or guarantees, express or implied, regarding the products or services described herein or their use or applicability. We reserve the right to modify or improve the designs or specifications of such products at any time without notice.

Emerson Process Management Regulator Technologies, Inc. does not assume responsibility for the selection, use or maintenance of any product. Responsibility for proper selection, use and maintenance of any Emerson Process Management Regulator Technologies, Inc. product remains solely with the purchaser.