

September 2015

Type 63EG-98HM Pilot-Operated Relief Valve or Backpressure Regulator

WARNING

Failure to follow these instructions or to properly install and maintain this equipment could result in an explosion, fire and/or chemical contamination causing property damage and personal injury or death.

Fisher® relief valves or backpressure regulators must be installed, operated and maintained in accordance with federal, state and local codes, rules and regulations and Emerson Process Management Regulator Technologies, Inc. (Emerson™) instructions.

If a leak develops or if the outlet continually vents gas, service to the unit may be required. Failure to correct trouble could result in a hazardous condition. Only a qualified person must install or service the unit.

Installation, operation and maintenance procedures performed by unqualified personnel may result in improper adjustment and unsafe operation. Either condition may result in equipment damage or personal injury. Use qualified personnel when installing, operating and maintaining the Type 63EG-98HM Pilot-Operated Relief Valve or Backpressure Regulator.

Introduction

Scope of the Manual

This manual describes and provides instructions and a parts list for the Type 63EG-98HM relief valve or backpressure regulator. Instructions and parts lists for other equipment used with this valve are found in separate manuals.



W6866

Figure 1. Type 63EG-98HM Pilot-Operated Relief Valve or Backpressure Regulator

Product Description

The Type 63EG-98HM pilot-operated relief valve or backpressure regulator is used for gas or liquid applications. For applications up to 450°F / 232°C, the Type 63EG-98HM utilizes high temperature Ethylenepropylene (EPR) or Perfluoroelastomer (FFKM) elastomers for Class VI shutoff. If used in a corrosive service, Perfluoroelastomer (FFKM) and other elastomers are available options that offer superior resistance to heat and most corrosive chemicals. This unit is not an ASME certified device.



Type 63EG-98HM

Specifications

This section lists the specifications for Type 63EG-98HM relief valves or backpressure regulators. Factory specification is stamped on the nameplate fastened on the regulator at the factory.

<p>Main Valve Body Sizes and End Connection Styles⁽¹⁾ See Table 1</p> <p>Maximum Design Pressure⁽²⁾⁽³⁾ 600 psig / 41.4 bar or body rating limit, whichever is lower</p> <p>Maximum Operating Relief (Inlet) Pressure Including Build-up⁽²⁾⁽³⁾ 450 psig / 31.0 bar or body rating limit, whichever is lower</p> <p>Maximum Outlet Pressure⁽²⁾⁽³⁾ 450 psig / 31.0 bar</p> <p>Maximum Differential Pressure⁽²⁾ 400 psig / 27.6 bar</p> <p>Relief Set Pressure/Backpressure Control Ranges⁽⁴⁾ See Table 3</p> <p>Port Diameter and Valve Plug Travels See Table 2</p> <p>Differential and Build-up Pressure Requirements⁽²⁾ See Table 4</p>	<p>Temperature Capabilities⁽²⁾ Fluorocarbon (FKM): 0 to 300°F / -18 to 149°C Not acceptable in water in excess of 180°F / 82°C Ethylenepropylene (EPR): <i>Steel:</i> -20 to 350°F / -29 to 177°C <i>Stainless steel:</i> -40 to 350°F / -40 to 177°C Perfluoroelastomer (FFKM): 0 to 450°F / -18 to 232°C</p> <p>Main Valve Flow Characteristics Linear (standard) or Whisper Trim™ III Cage (optional)</p> <p>Pilot Control Line Connection 1/4 NPT</p> <p>Pilot Spring Case Connection 1/4 NPT</p> <p>Approximate Weights (Including pilot) NPS 2 / DN 50 body: 65 lbs / 29 kg NPS 3 / DN 80 body: 105 lbs / 48 kg NPS 4 / DN 100 body: 155 lbs / 70 kg NPS 6 / DN 150 body: 340 lbs / 154 kg NPS 8 x 6 / DN 200 x 150 body: 630 lbs / 286 kg</p>
--	--

1. Other ratings and end connections can usually be supplied; consult the local Sales Office.
2. The pressure/temperature limits in this Instruction Manual and any applicable standard limitation should not be exceeded.
3. Fluorocarbon (FKM) diaphragm is limited to 300 psig / 20.7 bar.
4. Set pressure is defined as the pressure at which the pilot starts-to-discharge.

Table 1. Body Sizes and End Connection Styles

MAIN VALVE BODY SIZE		END CONNECTION STYLE
NPS	DN	
2	50	NPT, ASME CL150 RF, CL300 RF, CL600 RF or PN 16/25/40 flanged
3, 4, 6	80, 100, 150	ASME CL150 RF, CL300 RF, CL600 RF or PN 16/25/40 flanged
8 x 6	200 x 150	ASME CL150 RF, CL300 RF and CL600 RF flanged

Table 2. Port Diameters and Valve Plug Travels

BODY SIZE		PORT DIAMETER		VALVE PLUG TRAVEL	
NPS	DN	In.	mm	In.	mm
2	50	2-3/8	60	1-1/8	29
3	80	3-3/8	86	1-1/2	38
4	100	4-3/8	111	2	51
6	150	7-3/16	183	2	51
8 x 6	200 x 150	7-3/16	183	2	51

Table 3. Relief Set Pressure or Backpressure Control Ranges

CONTROL PRESSURE RANGE ⁽¹⁾		PART NUMBER	COLOR	SPRING FREE LENGTH		SPRING WIRE DIAMETER	
psig	bar			In.	mm	In.	mm
15 to 35	1.0 to 2.4	ERCA04288A0	Yellow	2.50	63.5	0.207	5.26
25 to 75	1.7 to 5.2	ERAA01910A0	Green	2.595	65.9	0.234	5.94
70 to 140	4.8 to 9.7	ERAA01911A0	Red	2.44	62.0	0.283	7.19
130 to 200	9.0 to 13.8	ERAA02889A0	Blue	2.250	57.2	0.331	8.41
150 to 375 ⁽²⁾	10.3 to 25.9 ⁽²⁾	1N943427142	Unpainted	5.063	129	0.394	10.0

1. All springs may be backed off to 0 psig / 0 bar. However, highest capacities and best performances are obtained by using these springs in their recommended ranges.
2. 150 to 375 psig / 10.3 to 25.9 bar spring range is for the Type MR98HH pilot construction.

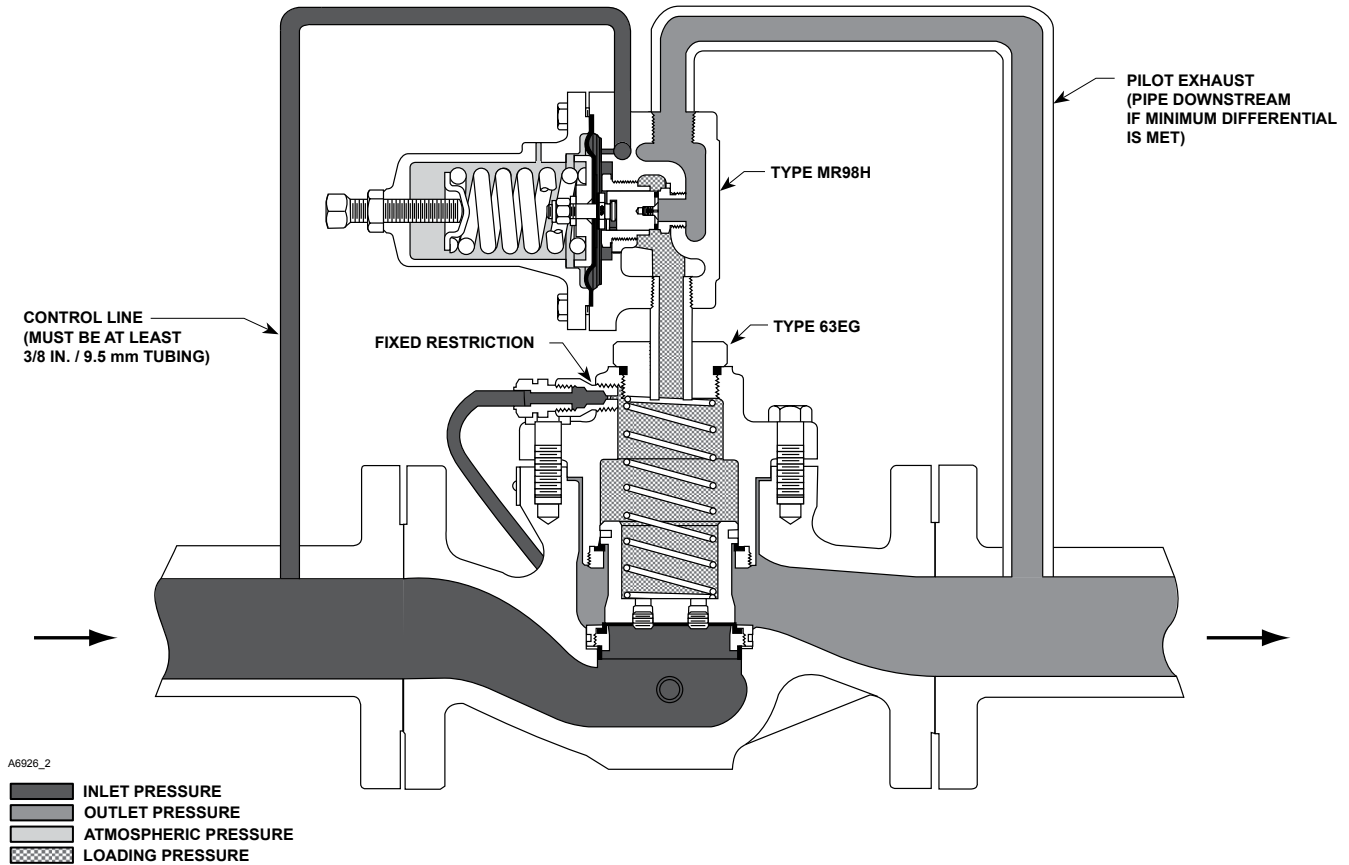

Note: On an actual Type 63EG-98HM, the pilot spring case points downstream.

Figure 2. Operational Schematic

Specifications

Specifications for a given construction as it originally comes from the factory are stamped on the main valve and pilot nameplates. The main valve nameplate is located on the main valve body. The pilot relief pressure range appears on the pilot nameplate.

Principle of Operation

As long as inlet pressure remains below set pressure, the pilot control spring keeps the pilot valve plug closed (Figure 2). This pressure provides the loading pressure to help the main valve spring keep the main valve plug tightly shutoff.

An inlet pressure rise above the set pressure overcomes the pilot control spring and opens the pilot valve plug. Loading pressure bleeds out the pilot exhaust faster than it can be replaced through the pilot restriction. This permits inlet pressure to unbalance the main valve plug and open the main valve. As inlet pressure drops below set pressure, the pilot control spring closes the pilot valve plug. Loading pressure again builds up to close the main valve plug.

Installation



Personal injury, equipment damage or leakage due to escaping gas (or liquid) or bursting of pressure-containing parts may result if the relief valve is installed where its capabilities can be exceeded or where conditions exceed any ratings of the adjacent piping or piping connections. To avoid this, install a Type 63EG-98HM relief valve where:

- Service conditions are within unit capabilities (including those given in the Specifications section)
- Service conditions are within applicable codes, regulations or standards

Additionally, physical damage to the relief valve could break the pilot off the main valve, causing personal injury and property damage due to escaping gas (or liquid). To avoid such injury or damage, install the unit in a safe location.

Type 63EG-98HM

Table 4. Minimum and Maximum Differential and Build-up Required for Wide-Open Flow

BODY SIZE, NPS / DN	MAIN VALVE SPRING RANGE, SPRING PART NUMBER AND COLOR	MINIMUM DIFFERENTIAL PRESSURE REQUIRED FOR FULL STROKE ⁽¹⁾		BUILD-UP OVER SET PRESSURE REQUIRED FOR FULL STROKE		MAXIMUM DIFFERENTIAL PRESSURE	
		psi	bar	psi	bar	psi	bar
2 / 50	10 to 40 psig / 0.69 to 2.8 bar 14A6768X012 Yellow	22	1.5	7	0.48	40	2.8
	30 to 125 psig / 2.1 to 8.6 bar 14A6626X012 Green	30	2.1	9	0.6	125	8.6
	85 to 400 psig / 5.9 to 27.6 bar 14A6628X012 Red	90	6.2	23	1.6	400 ⁽²⁾	28 ⁽²⁾
3 / 80	10 to 40 psig / 0.69 to 2.8 bar 14A6771X012 Yellow	19	1.3	5	0.34	40	2.8
	30 to 125 psig / 2.1 to 8.6 bar 14A6629X012 Green	25	1.7	7	0.48	125	8.6
	85 to 400 psig / 5.9 to 27.6 bar 14A6631X012 Red	60	4.1	17	1.2	400 ⁽²⁾	28 ⁽²⁾
4 / 100	10 to 40 psig / 0.69 to 2.8 bar 14A6770X012 Yellow	16	1.1	4	0.28	40	2.8
	30 to 125 psig / 2.1 to 8.6 bar 14A6632X012 Green	20	1.4	6	0.4	125	8.6
	85 to 400 psig / 5.9 to 27.6 bar 14A6634X012 Red	55	3.8	16	1.1	400 ⁽²⁾	28 ⁽²⁾
6, 8 x 6 / 150, 200 x 150	10 to 40 psig / 0.69 to 2.8 bar 15A2253X012 Yellow	16	1.1	4	0.28	40	2.8
	30 to 125 psig / 2.1 to 8.6 bar 14A9686X012 Green	20	1.4	6	0.4	125	8.6
	85 to 400 psig / 5.9 to 27.6 bar 15A2615X012 Red	55	3.8	16	1.1	400 ⁽²⁾	28 ⁽²⁾

1. Minimum differential is defined as the difference between the inlet pressure to the main valve body and the exhaust pressure from the pilot outlet. If the pilot exhaust is piped to the immediate downstream system, the differential is between the inlet and outlet pressure of the backpressure regulator. The pilot exhaust also may be discharged to atmosphere.
2. CL150 steel body is limited to 290 psig / 20 bar.

1. Call a qualified personnel when installing, operating, and maintaining relief valves and backpressure regulators. Before installing, inspect the main valve, pilot and tubing for any shipment damage or foreign material that may have collected during crating and shipment. Make certain the body interior is clean and the pipelines are free of foreign material. Apply pipe compound only to the external pipe threads with an NPT body, or use suitable line gaskets and good bolting practices with a flanged body.
2. A Type 63EG-98HM may be installed in any orientation, as long as flow through the valve matches the direction of the arrow on the main valve body.

prevent such injury or damage, provide piping or tubing to vent the gas (or liquid) to a safe location. The exhaust piping must be designed and installed to guard against excessive flow restriction. This piping must be protected against condensation or anything else that could clog it.

For safety during shutdown, vent valves are required immediately upstream and downstream of the main valve on a backpressure or bypass installation.

3. If system operation is necessary during maintenance or inspection, install isolating and vent valves as needed.
4. A relief valve must be installed so that the pilot exhausts properly and in a safe place. Make sure to keep the pilot spring case vent open to atmospheric pressure.
5. If the exhaust is to be piped to the main valve outlet or remotely vented, install obstruction-free tubing or piping with a minimum number of bends into the 1/2 NPT pilot exhaust connection.

WARNING

Type 63EG relief valves vent from the main valve outlet and from the pilot exhaust. In hazardous or flammable gas service, personal injury, death or property damage may occur due to fire or explosion or exposure of vented gas (or liquid) that has accumulated. To

6. If using pipe, apply a good grade of pipe compound to the external pipe threads before making the connection. Install tubing or piping into the appropriate pilot connection.
7. Set pressure is defined as the pressure at which the pilot starts to discharge. The set pressure of a unit is adjusted by changing the control spring compression on the pilot, by using the adjusting screw.
8. Each pilot is factory set for the relief set pressure specified on the order. If no setting is specified, set pressure is factory set at the midrange of the pilot control spring.

Startup and Adjustment

Key numbers are referenced in Figures 4, 5 and 6 unless otherwise indicated.

1. With proper installation and adjustment completed, slowly open the upstream shutoff valve while using gauges to monitor pressure. On backpressure or bypass applications using an isolating bypass, also open the downstream shutoff valve and close the bypass valve.
2. If set pressure adjustment is necessary, monitor inlet pressure with a gauge during the adjustment procedure.

Pilot Adjustment

Adjust the set pressure by loosening the pilot jam nut (key 17) and turning the pilot adjusting screw (key 15) clockwise to increase or counterclockwise to decrease the set pressure. When the required set pressure is maintained for several minutes, tighten the jam nut to lock the adjusting screw in position.

Shutdown

Relief Installations

Slowly close the upstream shutoff valve. Release all pressure from the main valve and pilot by opening the upstream vent valve.

Backpressure or Bypass Installations

Slowly close the upstream shutoff valve while opening the bypass valve if an isolating bypass is used. Then close the downstream shutoff valve and open both vent valves to release all pressure from the main valve and pilot.

Maintenance

Relief valve and backpressure regulator parts are subject to normal wear and must be inspected and replaced as necessary. The frequency of inspection and replacement of parts depends upon the severity of service conditions or the requirements of local, state and federal regulations. Due to the care Emerson™ takes in meeting all manufacturing requirements (heat treating, dimensional tolerances, etc.), use only replacement parts manufactured or furnished by Emerson. All O-rings, gaskets and seals should be lightly lubricated with a good grade of general purpose grease and installed gently rather than forced into position. Be certain that the nameplates are updated to accurately indicate any field changes in equipment, materials, service conditions or pressure settings.



WARNING

To avoid personal injury and equipment damage, isolate the valve from all pressure. Cautiously release pressure from the valve before attempting disassembly.

Type 63EG Main Valve

Replacing Trim Parts

Perform this procedure if inspecting, cleaning or replacing individual parts in the trim package. Key numbers for the Type 63EG main valve are referenced in Figures 4 and 5.

Note

Access to the spring (key 9) or flange O-ring (key 21) in step 1 can be gained without removing the body flange (key 2).

1. Remove the pilot and pilot pipe nipple from the valve body. Remove the body flange plug (key 27) and the spring (key 9) and attached parts. Proceed to step 5 if only performing maintenance on these parts.
2. Remove the cap screws (key 3) and pry the body flange (key 2) loose from the valve body (key 1).
3. The valve body (key 1) can be used as a holding fixture by flipping the body flange over and anchor it on the valve body as shown in Figure 3.
4. To gain access to the port seal (key 12), upper seal (key 15) or valve plug parts, unscrew the seat ring (key 13) from the cage (key 11) and the cage from the body flange (key 2). For leverage, a wrench

Type 63EG-98HM



REPLACING ENTIRE TRIM PACKAGE

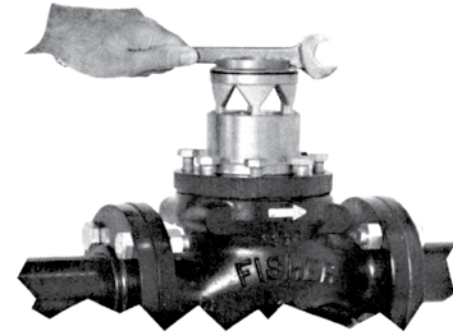

REPLACING TRIM PARTS ON SITE
USING BODY AS HOLDING FIXTURE

Figure 3. Easy Trim Maintenance

handle or similar tool may be inserted into the orifice slots (Figure 3) and a strap wrench may be wrapped around the cage or a soft bar may be inserted through the windows of a standard cage. To remove the piston ring (key 14) and/or plug O-ring (key 20), remove the valve plug (key 16) from the body flange, insert a screw-driver into the pre-cut fold over area of the piston ring and unfold the piston ring.

- Replace parts such as the gasket (key 4) and cage O-ring (key 17) if worn or damaged, making sure that if the port seal (key 12) and upper seal (key 15) were removed they are installed in their retaining slots with the grooved sides facing out. Lightly lubricate seating surfaces and parts as necessary for ease of installation. For proper operation, a Type 63EG valve plug must have pipe plugs (key 31) installed in all four balancing ports.
- Install the plug O-ring (key 20) and piston ring (key 14) onto the valve plug (key 16). Insert the valve plug into the body flange (key 2), install the cage (key 11) plus upper seal (key 15) and cage O-ring (key 17) into the body flange and then install the seat ring (key 13) plus port seal (key 12) into the cage. Use the valve body as a holding fixture during this step as shown in Figure 3 and insert a wrench handle or similar tool into the orifice slots for leverage when tightening the orifice and cage.

Note

When installing the trim package, align the body flange and valve body side tappings.

- Remove the upside-down body flange (key 2) if it was anchored on the body. Lightly lubricate the cage seating surfaces of the valve body web and the body flange. Install the body flange on the body (key 1) and secure it evenly with the cap

screws or stud bolts (key 3). Install the pilot and its pipe nipple and connect the pilot tubing.

- Install the spring (key 9) and place the flange O-ring (key 21) on the flange plug (key 27). Install the flange plug; if necessary, compress the spring enough to ensure secure engagement of plug and body flange threads before final tightening of the plug.

Type MR98H Pilot

WARNING

To avoid personal injury, property damage or equipment damage caused by sudden release of pressure or uncontrolled process fluid, do not attempt any maintenance or disassembly without first isolating the regulator from system pressure and relieving all internal pressure from the regulator.

Relief valves or regulators that have been disassembled for repair must be tested for proper operation before being returned to service. Only parts manufactured by Emerson™ should be used for repairing Fisher® relief valves and regulators.

Due to normal wear and damage that may occur from external sources, relief valve parts such as the O-rings, gaskets, diaphragm, orifice and valve plug should be inspected periodically and replaced as necessary. The frequency of inspection and replacement depends upon the severity of service conditions or the requirements of state and federal laws.

The following instructions explain the disassembly of the Type MR98H relief or backpressure pilot. Lightly apply a good quality lubricant when reassembling. Key numbers are referenced in Figure 7.

Type 63EG-98HM

Table 5. Type 63EG Main Valve Body Part Numbers (Key 1)

BODY MATERIAL	END CONNECTION STYLE	PART NUMBER				
		NPS 2 / DN 50	NPS 3 / DN 80	NPS 4 / DN 100	NPS 6 / DN 150	NPS 8 x 6 / DN 200 x 150
WCB Steel	NPT	38A8848X012	-----	-----	-----	-----
	CL150 RF flanged	38A8853X012	38A8872X012	38A8867X012	38A7115X012	GE05973X012
	CL300 RF flanged	38A8849X012	38A8871X012	38A8869X012	38A8873X012	GE05974X012
	CL600 RF flanged	38A8844X012	38A8852X012	38A8866X012	38A8874X012	GE05975X012
	PN 16/25/40 RF	GE05960X012	GE05965X012	GE05969X012	GE05972X012	Contact local Sales Office
WCB Steel (NACE)	NPT	38A8848X022	-----	-----	-----	-----
	CL150 RF flanged	38A8853X052	38A8872X062	38A8867X032	38A7115X022	Contact local Sales Office
	CL300 RF flanged	38A8849X022	38A8871X042	38A8869X022	38A8873X022	Contact local Sales Office
	CL600 RF flanged	38A8844X022	38A8852X032	38A8866X022	38A8874X022	Contact local Sales Office
CF8M Stainless steel	NPT	38A8848X032	-----	-----	-----	-----
	CL150 RF flanged	38A8853X072	38A8872X052	38A8867X042	38A7115X032	Contact local Sales Office
	CL300 RF flanged	38A8849X032	38A8871X052	38A8869X032	38A8873X032	Contact local Sales Office
	CL600 RF flanged	38A8844X032	38A8852X042	38A8866X032	38A8874X032	Contact local Sales Office
	PN 16/25/40 RF	GE05960X022	GE05965X022	GE05969X022	GE05972X022	Contact local Sales Office

Table 6. Type 63EG Main Valve Spring Part Numbers (Key 9)

BODY SIZE, NPS / DN	SPRING RANGE					
	Standard			NACE		
	10 to 40 psig / 0.69 to 2.8 bar	30 to 125 psig / 2.1 to 8.6 bar	85 to 400 psig / 5.9 to 27.6 bar	10 to 40 psig / 0.69 to 2.8 bar	30 to 125 psig / 2.1 to 8.6 bar	85 to 400 psig / 5.9 to 27.6 bar
2 / 50	14A6678X012	14A6626X012	14A6628X012	16A5502X012	16A5501X012	16A5499X012
3 / 80	14A6771X012	14A6629X012	14A6631X012	16A5505X012	16A5503X012	16A5500X012
4 / 100	14A6770X012	14A6632X012	14A6634X012	16A5507X012	16A5506X012	16A5998X012
6 and 8 x 6 / 150 and 200 x 150	15A2253X012	14A9686X012	15A2615X012	16A5509X012	16A5510X012	16A6000X012

- Shut down the backpressure regulator or relief valve.
- Relieve the spring tension by loosening the jam nut (key 17) and turning the adjusting screw (key 15) counterclockwise. Remove cap screws (key 16) and lift off the spring case (key 2), upper spring seat (key 9) and relief valve spring (key 11).
- Lift out the diaphragm unit which includes the lock nut (key 31), lock washer (key 28), pusher post (key 10), gasket (key 29), lower spring seat (key 8), diaphragm (key 12) and valve plug (key 4).
- Check the orifice (key 3) for wear or damage. If it needs to be replaced, unscrew the valve plug guide (key 7) and then the orifice. The valve plug (key 4) can be removed by sliding it off of the pusher post (key 10).
- Place a small amount of sealant on the threads of the orifice (key 3) and valve plug guide (key 7) and reinstall these to the body (key 1).
- To replace the valve plug O-ring (key 53), remove the machine screw (key 24) and O-ring retainer (key 25) from the plug. Remove and replace the O-ring.
- Separate the remainder of the diaphragm unit parts. Take the lock nut (key 31) off of the pusher post (key 10). Slide off the lock washer (key 28), lower spring seat (key 8), diaphragm (key 12), washer (key 58) and gasket (key 29).
- Slip the valve plug (key 4) onto the pusher post (key 10). Place a gasket (key 29) on the shaft of the pusher post over the threaded portion until it rests on the base of the post. The printed side should be facing upwards when installed. Place a metal washer (key 58) on top of the gasket.
- Slip the lower spring seat (key 8) and lock washer (key 28) back onto the pusher post (key 10). Lubricate the threads of the pusher post and tighten the pusher post lock nut (key 31) until the lock washer is flat and then turn the nut an additional 1/8 to 1/4 turn. Return the diaphragm (key 12), spring seat and pusher post assembly to the body (key 1).
- Set the relief valve spring (key 11) in the lower spring seat and place the upper spring seat (key 9) on the spring.
- Put the spring case (key 2) over the spring (key 11) and onto the body (key 1). Tighten the cap screws (key 16) finger tight only.
- To ensure proper slack in the diaphragm (key 12), apply some spring compression by turning the adjusting screw (key 15) clockwise. Finish tightening the cap screws (key 16) with 10 to 13 ft-lbs / 13.56 to 17.63 N•m of torque.

Type 63EG-98HM

Parts Ordering

Each Type 63EG-98HM is assigned a serial number or FS number which can be found on the nameplates. Refer to this number when contacting your local Sales Office.

When ordering a replacement part, be sure to include the 11-character part number found in the Parts List. Separate kits containing all recommended spare parts are available for both the main valve and pilot.

Parts List

Type 63EG Main Valve

Key	Description	Part Number
	Parts Kit for WCC Steel Bodies (includes keys: 4, 7, 12, 14, 15, 17, 20 and 21)	
	NPS 2 / DN 50 body	
	Fluorocarbon (FKM)	R63EGXFK122
	Ethylenepropylene (EPR)	R63EGXEP122
	NPS 3 / DN 80 body	
	Fluorocarbon (FKM)	R63EGXFK132
	Ethylenepropylene (EPR)	R63EGXEP132
	NPS 4 / DN 100 body	
	Fluorocarbon (FKM)	R63EGXFK142
	Ethylenepropylene (EPR)	R63EGXEP142
	NPS 6 / DN 150 body	
	Fluorocarbon (FKM)	R63EGXFK162
	Ethylenepropylene (EPR)	R63EGXEP162
1	Main Valve Body	See Table 5
2	Body Flange	
	NPS 2 / DN 50 body	
	WCC Steel	25A2254X012
	CF8M Stainless steel	25A2254X082
	NPS 3 / DN 80 body	
	WCC Steel	25A2300X012
	CF8M Stainless steel	25A2300X122
	NPS 4 / DN 100 body	
	WCC Steel	24A9032X012
	CF8M Stainless steel	24A9032X042
	NPS 6 / DN 150 body	
	WCC Steel	34A7152X012
	CF8M Stainless steel	34A7152X052
3	Cap Screw for Steel body	
	NPS 2 / DN 50 body (8 required)	1A453324052
	NPS 3 / DN 80 body (8 required)	1A454124052
	NPS 4 / DN 100 body (8 required)	1A485724052
	NPS 6 / DN 150 body (12 required)	1U513124052
	Stud Bolt for Stainless steel body	
	NPS 2 / DN 50 body (8 required)	1K242935222
	NPS 3 / DN 80 body (8 required)	1A378135222
	NPS 4 / DN 100 body (8 required)	1R369035222
	NPS 6 / DN 150 body (12 required)	1A365635222
4*	Gasket	
	NPS 2 / DN 50 body	
	Composition	14A5685X012
	Graphite	14A5685X072
	NPS 3 / DN 80 body	
	Composition	14A5665X012
	Graphite	14A5665X022
	NPS 4 / DN 100 body	
	Composition	14A5650X012
	Graphite	14A5650X062
	NPS 6 / DN 150 body	
	Composition	14A6984X012
	Graphite	14A6984X032

Key	Description	Part Number
9	Spring	See Table 6
11*	Cage	
	NPS 2 / DN 50 body	
	316 Stainless steel Linear Cage	34B5838X012
	416 Stainless steel Whisper Trim™ Cage	24A5707X012
	316 Stainless steel Whisper Trim Cage	24A5707X022
	NPS 3 / DN 80 body	
	316 Stainless steel Linear Cage	34B5839X012
	416 Stainless steel Whisper Trim Cage	24A5708X012
	316 Stainless steel Whisper Trim Cage	24A5708X042
	NPS 4 / DN 100 body	
	316 Stainless steel Linear Cage	34B5840X012
	416 Stainless steel Whisper Trim Cage	24A5709X012
	316 Stainless steel Whisper Trim Cage	24A5709X022
	NPS 6 / DN 150 body	
	316 Stainless steel Linear Cage	34B5841X012
	416 Stainless steel Whisper Trim Cage	24A8174X012
	316 Stainless steel Whisper Trim Cage	24A8174X022
12*	Port Seal	
	NPS 2 / DN 50 body	
	Fluorocarbon (FKM)	25A7412X012
	Perfluoroelastomer (FFKM)	24A5673X082
	Ethylenepropylene (EPR)	24A5673X062
	NPS 3 / DN 80 body	
	Fluorocarbon (FKM)	25A7375X012
	Perfluoroelastomer (FFKM)	24A5658X052
	Ethylenepropylene (EPR)	24A5658X062
	NPS 4 / DN 100 body	
	Fluorocarbon (FKM)	25A7469X012
	Perfluoroelastomer (FFKM)	24A5643X032
	Ethylenepropylene (EPR)	24A5643X052
	NPS 6 / DN 150 body	
	Fluorocarbon (FKM)	14A6996X012
	Perfluoroelastomer (FFKM)	14A8175X042
	Ethylenepropylene (EPR)	14A8175X022
13*	Seat Ring	
	NPS 2 / DN 50	
	416 Stainless steel	24A5670X012
	316 Stainless steel	24A5670X022
	NPS 3 / DN 80	
	416 Stainless steel	24A5655X012
	316 Stainless steel	24A5655X022
	NPS 4 / DN 100	
	416 Stainless steel	24A5640X012
	316 Stainless steel	24A5640X022
	NPS 6 / DN 150	
	416 Stainless steel	24A6989X012
	316 Stainless steel	24A6989X022
	NPS 8x6 / DN 200x150	
	416 Stainless steel	38A4216X012
14*	Piston Ring	
	NPS 2 / DN 50 body	
	Polytetrafluoroethylene (PTFE)	14A5675X012
	NPS 3 / DN 80 body	
	Polytetrafluoroethylene (PTFE)	14A5660X012
	NPS 4 / DN 100 body	
	Polytetrafluoroethylene (PTFE)	14A5645X012
	NPS 6 / DN 150 body	
	Polytetrafluoroethylene (PTFE)	14A6985X022
15*	Upper Seal	
	NPS 2 / DN 50 body	
	Fluorocarbon (FKM)	25A7413X012
	Perfluoroelastomer (FFKM)	24A5674X082
	Ethylenepropylene (EPR)	24A5674X062
	NPS 3 / DN 80 body	
	Fluorocarbon (FKM)	25A7376X012
	Perfluoroelastomer (FFKM)	24A5659X052
	Ethylenepropylene (EPR)	24A5659X062

*Recommended spare part

- continued -

Type 63EG-98HM

Type 63EG Main Valve (continued)

Key	Description	Part Number	Key	Description	Part Number
15*	Upper Seal (continued)		26	Nameplate	-----
	NPS 4 / DN 100 body		27	Travel Indicator Plug	
	Fluorocarbon (FKM)	25A7468X012		Steel	
	Perfluoroelastomer (FFKM)	24A5644X032		NPS 2, 3 and 4 / DN 50, 80 and 100 bodies	17B4894X012
	Ethylene propylene (EPR)	24A5644X052		NPS 6 / DN 150	17B4893X032
	NPS 6 / DN 150 body			Stainless steel	
	Fluorocarbon (FKM)	14A8185X012		NPS 2, 3 and 4 / DN 50, 80 and 100 bodies	17B4894X022
	Perfluoroelastomer (FFKM)	14A8176X042		NPS 6 / DN 150 body	17B4893X032
	Ethylene propylene (EPR)	14A8176X022	29	Hex Nut - for stainless steel bodies	
16*	Valve Plug			NPS 2 / DN 50 (8 required)	1A377235252
	NPS 2 / DN 50			NPS 3 / DN 80 (8 required)	1A376035252
	416 Stainless steel	24A6772X012		NPS 4 / DN 100 (8 required)	1A352035252
	316 Stainless steel	24A6772X032		NPS 6 / DN 150 (12 required)	1A440935252
	NPS 3 / DN 80		31	Pipe Plug (4 required)	
	416 Stainless steel	24A9421X012		416 Stainless steel	1E823128982
	316 Stainless steel	24A9421X022		316 Stainless steel	1E8231X0012
	NPS 4 / DN 100		32	NACE Tag	-----
	416 Stainless steel	24A8182X012	33	Tag Wire	-----
	316 Stainless steel	24A8182X022	34	Pipe Nipple	
	NPS 6 and 8 x 6 / DN 150			Standard	1B828626012
	and 200 x 150			NACE	1B8286X0012
	416 Stainless steel	24A6992X012	35	Tubing	-----
	316 Stainless steel	24A6992X022	36*	Restrictor	
17*	Cage O-ring			Standard	17B5175X022
	NPS 2 / DN 50 body			NACE	17B5175X012
	Fluorocarbon (FKM)	10A7779X022	37	Connector (2 required, 4 for Type MR98H	
	Perfluoroelastomer (FFKM)	10A7779X132		with Needle valve)	15A6002X602
	Ethylene propylene (EPR)	10A7779X052	39	Pipe Nipple, Zinc-plated steel	
	NPS 3 / DN 80 body			(for option with needle valve, 2 required)	1C559926232
	Fluorocarbon (FKM)	14A5688X022	40	Tee, Carbon steel (for option	
	Perfluoroelastomer (FFKM)	14A5688X112		with needle valve, 2 required)	1B8606X0032
	Ethylene propylene (EPR)	14A5688X082	41	Needle Valve, Stainless steel (for option	
	NPS 4 / DN 100 body			with needle valve)	1R2214X0372
	Fluorocarbon (FKM)	10A3483X012	45	Pipe plug	
	Perfluoroelastomer (FFKM)	10A3481X032		Carbon Steel (not available for	
	Ethylene propylene (EPR)	10A3481X052		8 x 6 in. / DN 200 x 150)	1A398524182
	NPS 6 / DN 150 body			316 Stainless steel	1A398535072
	Fluorocarbon (FKM)	18A2556X032	Type MR98H Pilot		
	Perfluoroelastomer (FFKM)	18A2556X062	Key	Description	Part Number
	Ethylene propylene (EPR)	18A2556X072		Parts Kit (included are keys 3, 4,	
20*	Plug O-ring			12, 29, 59 and 63)	
	NPS 2 / DN 50 body			With Stainless steel diaphragm and trim	RMR98HX0052
	Fluorocarbon (FKM)	14A5686X022	1	Regulator Body, 1/2 NPT	
	Perfluoroelastomer (FFKM)	14A5686X072		WCC Steel	ERAA01934A1
	Ethylene propylene (EPR)	14A5686X052		CF8M Stainless steel	ERAA01934A3
	NPS 3 / DN 80 body		2	Spring Case, 1/4 NPT Tapped Vent	
	Fluorocarbon (FKM)	1V3269X0042		Use with all other springs	
	Perfluoroelastomer (FFKM)	1V3269X0082		WCC Steel	ERAA01886A0
	Ethylene propylene (EPR)	1V3269X0062		CF8M Stainless steel	ERAA01886A1
	NPS 4 / DN 100 body			Use with 150 to 375 psig / 10.3 to 25.9 bar spring	
	Fluorocarbon (FKM)	14A5688X022		WCC Steel	ERCA00619A0
	Perfluoroelastomer (FFKM)	14A5688X112		CF8M Stainless steel	ERCA00619A2
	Ethylene propylene (EPR)	14A5688X082	3*	Orifice	
	NPS 6 / DN 150 body			416 Stainless steel	GF05552X022
	Fluorocarbon (FKM)	1V547606382		316 Stainless steel, NACE	GF05552X032
	Perfluoroelastomer (FFKM)	1K8793X0022	4*	Valve Plug	
	Ethylene propylene (EPR)	1K8793X0012		416 Stainless steel	ERCA01333A0
21*	O-ring			316 Stainless steel, NACE	ERCA01333A1
	NPS 2, 3 and 4 / DN 50, 80 and 100 bodies		5	Bottom Plug	
	Fluorocarbon (FKM)	1R727606382		416 Stainless steel	GF05532X022
	Perfluoroelastomer (FFKM)	10A3800X062		316 Stainless steel, NACE	GF05532X032
	Ethylene propylene (EPR)	10A3800X042	7	Valve Plug Guide	
	NPS 6 / DN 150 body			416 Stainless steel	GF05534X022
	Fluorocarbon (FKM)	1F2629X0012		316 Stainless steel, NACE	GF05534X032
	Perfluoroelastomer (FFKM)	1F2629X0042			
	Ethylene propylene (EPR)	1F2629X0032			
24	Drive Screw (4 required)	1A368228982			
25	Flow Arrow	-----			

*Recommended spare part

- continued -

Type 63EG-98HM

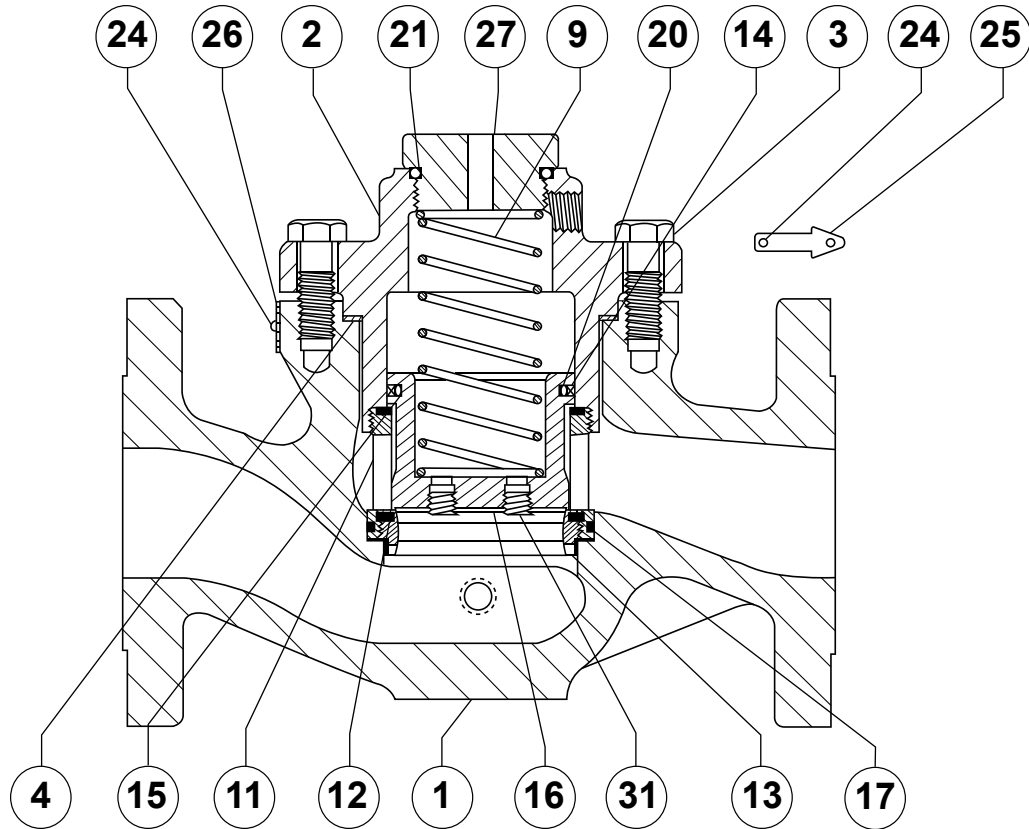

35A3174-A
A2812

Figure 4. Type 63EG Main Valve

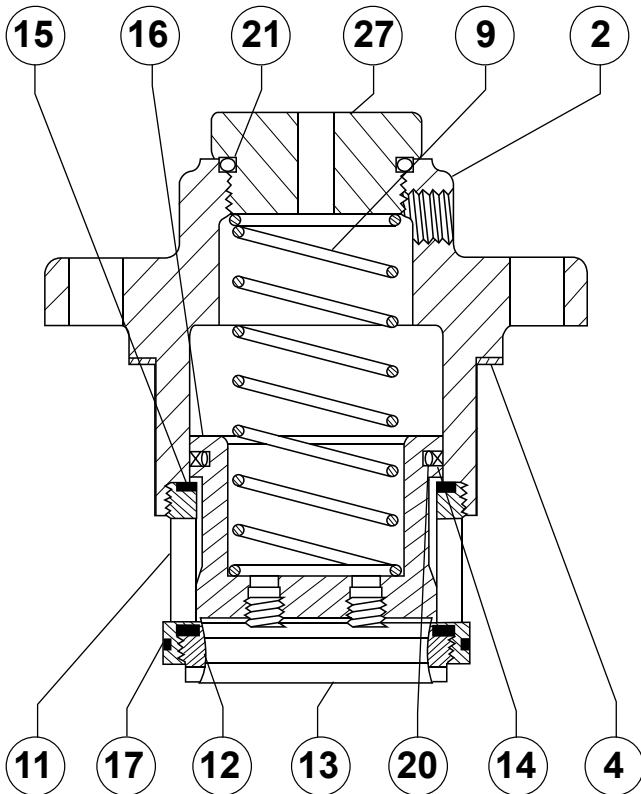

35A3174-A
A2812

Figure 5. Type 63EG Main Valve Trim Package

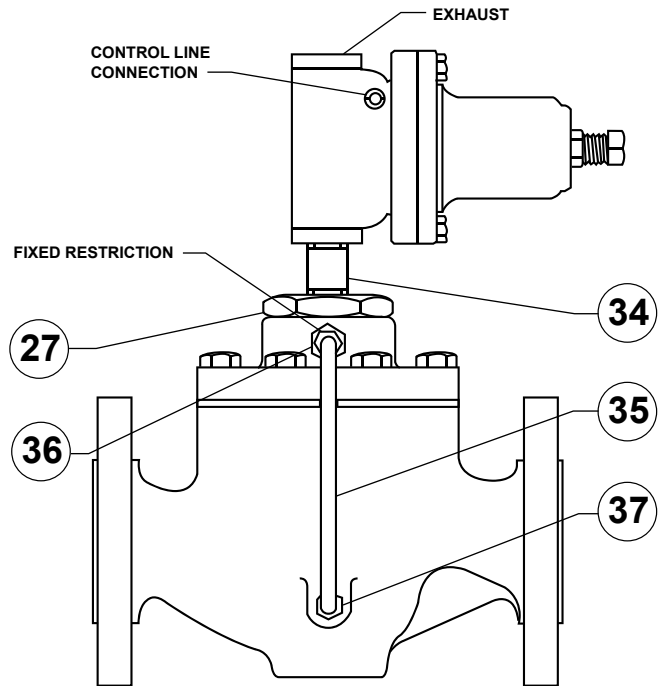

37B5269
E0387

Figure 6. Type 63EG-98HM Mounting Parts

Type 63EG-98HM

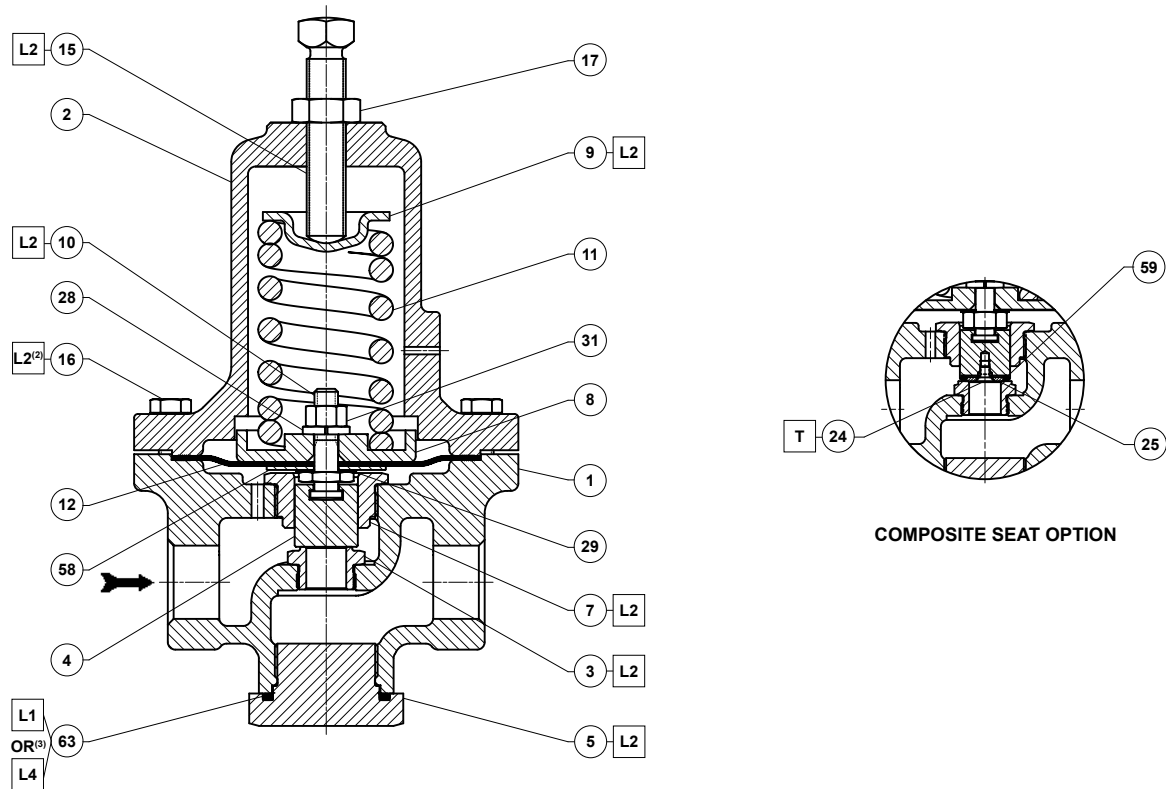

GF04916

APPLY⁽¹⁾:

T = THREAD LOCKER

L1 = GENERAL PURPOSE PTFE OR LITHIUM GREASE FOR O-RINGS

L2 = ANTI - SEIZE COMPOUND

L4 = GRAPHITE SEALANT FOR GRAPHITE RING

1. Lubricants and sealants must be selected such that they meet the temperature requirements.

2. Apply L2 (anti-seize compound) on key 16 for stainless steel bolts.

3. Apply L4 (graphite sealant) instead of L1 (general purpose PTFE or lithium grease) on key 63 for graphite ring.

Figure 7. Type MR98H

Type MR98H Pilot (continued)

Key	Description	Part Number	Key	Description	Part Number
8	Lower Spring Seat Use with all other springs Aluminum Stainless steel Use with 150 to 375 psig / 10.3 to 25.9 bar spring Aluminum Stainless steel	1L339708012 1L3397X0012 1N943024272 1N9430X0012	11	Control Spring (continued) 70 to 140 psig / 4.8 to 9.7 bar, Powder-coated steel, Red 130 to 200 psig / 9.0 to 13.8 bar, Powder-coated steel, Blue 150 to 375 psig / 10.3 to 25.9 bar, Powder-coated steel, Unpainted	ERAA01911A0 ERAA02889A0 1N943427142
9	Upper Spring Seat Use with all other springs Steel Stainless steel Use with 150 to 375 psig / 10.3 to 25.9 bar spring Steel Stainless steel	ERCA00823A0 ERCA00823A1 ERCA00430A0 ERCA00430A1	12*	Diaphragm (2 required) Fluorocarbon (FKM) EPDM 302 Stainless steel	ERCA00512A1 ERCA00512A2 ERCA00496A0
10*	Pusher Post 416 Stainless steel 316 Stainless steel, NACE	ERCA01344A0 ERCA01344A1	13	Nameplate	-----
11	Control Spring 15 to 35 psig / 1.0 to 2.4 bar, Powder-coated steel, Yellow 25 to 75 psig / 1.7 to 5.2 bar, Powder-coated steel, Green	ERCA04288A0 ERAA01910A0	14	Diaphragm Protector, PTFE (if required)	11A5136X012
			15	Adjusting Screw Use with all other springs Use with 150 to 375 psig / 10.3 to 25.9 bar spring	GF05553X012 ERAA02340A0
			16	Cap Screw (8 required) Steel Stainless steel	ERCA00100A0 ERCA00100A1
			17	Jam Nut, Steel	ERCA00380A0
			18	Drive Screw, (4 required)	ERAA01884A0
			24	Machine Screw, Stainless steel	1J4159X0012

*Recommended spare part

- continued -

Type 63EG-98HM

Type MR98H Pilot (continued)

Key	Description	Part Number	Key	Description	Part Number
25	O-ring Retainer 416 Stainless steel	1L341535232	58	Washer 416 Stainless steel	GF05050X012
	316 Stainless steel, NACE	1L341535072		316 Stainless steel	GF05050X022
28	Lock Washer Steel	ERAA01919A0	59*	Valve Plug O-ring Fluorocarbon (FKM) seat	1D2888X0052
	Stainless steel	ERAA01919A1		Ethylene Propylene (EPDM) seat	1N5301X0012
29*	Gasket, Composition	ERAA02651A0		Perfluoroelastomer (FFKM) seat	1N5301X0022
31	Locknut, Steel	ERCA00663A0	63*	Bottom Plug Seal Fluorocarbon (FKM)	ERCA03016A1
51	Vent, Type Y602-12	ERAA02123A0		Ethylene Propylene (EPDM)	ERCA03016A2
53*	Valve Plug Sealing O-ring Fluorocarbon (FKM)	ERCA02968A1	64	Flow arrow	-----
	Ethylene Propylene (EPDM)	ERCA02968A2			
	Perfluoroelastomer (FFKM)	ERCA02968A3			

*Recommended spare part

Industrial Regulators

Emerson Process Management Regulator Technologies, Inc.

USA - Headquarters
McKinney, Texas 75070 USA
Tel: +1 800 558 5853
Outside U.S. +1 972 548 3574

Asia-Pacific
Shanghai 201206, China
Tel: +86 21 2892 9000

Europe
Bologna 40013, Italy
Tel: +39 051 419 0611

Middle East and Africa
Dubai, United Arab Emirates
Tel: +971 4811 8100

Natural Gas Technologies

Emerson Process Management Regulator Technologies, Inc.

USA - Headquarters
McKinney, Texas 75070 USA
Tel: +1 800 558 5853
Outside U.S. +1 972 548 3574

Asia-Pacific
Singapore 128461, Singapore
Tel: +65 6770 8337

Europe
Bologna 40013, Italy
Tel: +39 051 419 0611
Chartres 28008, France
Tel: +33 2 37 33 47 00

Middle East and Africa
Dubai, United Arab Emirates
Tel: +971 4811 8100

TESCOM

Emerson Process Management Tescom Corporation

USA - Headquarters
Elk River, Minnesota 55330-2445, USA
Tels: +1 763 241 3238
+1 800 447 1250

Europe
Selmsdorf 23923, Germany
Tel: +49 38823 31 287

Asia-Pacific
Shanghai 201206, China
Tel: +86 21 2892 9499

For further information visit www.fisherregulators.com

The Emerson logo is a trademark and service mark of Emerson Electric Co. All other marks are the property of their prospective owners. Fisher is a mark owned by Fisher Controls International LLC, a business of Emerson Process Management.

The contents of this publication are presented for informational purposes only, and while every effort has been made to ensure their accuracy, they are not to be construed as warranties or guarantees, express or implied, regarding the products or services described herein or their use or applicability. We reserve the right to modify or improve the designs or specifications of such products at any time without notice.

Emerson Process Management Regulator Technologies, Inc. does not assume responsibility for the selection, use or maintenance of any product. Responsibility for proper selection, use and maintenance of any Emerson Process Management Regulator Technologies, Inc. product remains solely with the purchaser.