

Introduction

This installation guide provides instructions for installation, startup, and adjustment. To receive a copy of the instruction manual, contact your local Fisher Sales Office or Sales Representative or view a copy at www.FISHERregulators.com. For further information refer to:

Type EZR Instruction Manual, form 5468, D102600X012.

The Type EZR pilot-operated, pressure reducing regulators are used for natural gas, air, or other non-corrosive gas applications and include a Type 112 restrictor and a 161EB Series or 161AY Series pilot. For applications that have high pressure drops, using a Type 161AYM, 161EBM, or 161EBHM monitor pilot will increase the accuracy of the regulator.

P.E.D. Categories

This product may be used as a safety accessory with pressure equipment in the following Pressure Equipment Directive 97/23/EC categories. It may also be used outside of the Pressure Equipment Directive using sound engineering practice (SEP) per table below.

PRODUCT SIZE	CATEGORIES	FLUID GROUP
DN 25 (1-inch)	SEP	1
DN 50, 50 x 25, 80, 100, 150, 200 x 150, and 300 x 150 (2, 2 x 1, 3, 4, 6, 8 x 6-inch)	I, II, III	

Specifications

Main Valve Body Sizes, End Connection Styles, and Structural Design Ratings⁽¹⁾

See table 1

Maximum Inlet Pressures and Pressure Drops⁽¹⁾

Main Valve: See table 6

Pilots: See table 3

Restrictor: 103 bar (1500 psig)

Outlet (Control) Pressure Ranges⁽¹⁾

See table 2

Minimum and Maximum Differential Pressures⁽¹⁾

See tables 4 and 6

Proof Test Pressure

All Pressure Retaining Components have been proof tested per Directive 97/23/EC - Annex 1, Section 7.4

1. The pressure/temperature limits in this installation guide and any applicable standard or code limitation should not be exceeded.

Table 1. Main Valve Body Sizes, End Connection Styles, and Body Ratings

MAIN VALVE BODY SIZE, DN (INCH)	MAIN VALVE BODY MATERIAL	END CONNECTION STYLES	STRUCTURAL DESIGN RATING, bar (psig)	PROOF TEST PRESSURE, bar (PSIG)
25, 50, 50 x 25, 80, 100, 150, 200 x 150 (1, 2 x 1, 2, 3, 4, 6, 8 x 6)	WCB Steel	NPT or SWE (DN 25, 50, 50 x 25 only)	102 (1480)	153 (2220)
		ANSI Class 150RF	19,6 (285)	29,5 (428)
		ANSI Class 300RF	51,0 (740)	76,5 (1110)
		ANSI Class 600RF or BWE	102 (1480)	153 (2220)

Temperature Capabilities⁽¹⁾

See table 5

Pilot Type Descriptions

Type 161AY—Low-pressure pilot with an outlet pressure range from 15 mbar to 0,48 bar (6-inches w.c. to 7 psig). Pilot bleeds (exhausts) downstream through the sense (control) line.

Type 161AYM—The monitor version of the Type 161AY pilot. The pilot bleed (exhaust) is isolated from the sense (control) line. This pilot is used in monitoring systems requiring an isolated pilot bleed (exhaust).

Type 161EB—High accuracy pilot with an outlet pressure range from 0,34 to 24,2 bar (5 to 350 psig). Pilot bleeds (exhausts) downstream through the sense (control) line.

Type 161EBM—The monitor version of the Type 161EB pilot. The pilot bleed (exhaust) is isolated from the sense (control) line. This pilot is used in monitoring systems requiring an isolated pilot bleed (exhaust).

Type 161EBH—The high-pressure version of the Type 161EB pilot with an outlet pressure range from 17,2 to 48,3 bar (250 to 700 psig).

Type 161EBHM—The high-pressure version of the Type 161EBM pilot with an outlet pressure range from 17,2 to 48,3 bar (250 to 700 psig).

Installation



WARNING

Only qualified personnel should install or service a regulator. Regulators should be installed, operated, and maintained in accordance with international and applicable codes and regulations, and Fisher instructions.

If the regulator vents fluid or a leak develops in the system, it indicates that service is required. Failure to take the regulator out of service immediately may create a hazardous condition.

Personal injury, equipment damage, or leakage due to escaping fluid or bursting of pressure-containing parts may result if this regulator is overpressured or is installed where service conditions could exceed the limits given in the Specifications section, or where conditions exceed any ratings of the adjacent piping or piping connections.



Patent Numbers 5,964,446 and 6,102,071
Additional Patents Pending

www.FISHERregulators.com



Type EZR

To avoid such injury or damage, provide pressure-relieving or pressure-limiting devices (as required by the appropriate code, regulation, or standard) to prevent service conditions from exceeding limits.

Additionally, physical damage to the regulator could result in personal injury and property damage due to escaping fluid. To avoid such injury and damage, install the regulator in a safe location.

Clean out all pipelines before installation of the regulator and check to be sure the regulator has not been damaged or has collected foreign material during shipping. For NPT bodies, apply pipe compound to the male pipe threads. For flanged bodies, use suitable line gaskets and approved piping and bolting practices. Install the regulator in any position desired, unless otherwise specified, but be sure flow through the body is in the direction indicated by the arrow on the body.

Table 2. Outlet (Control) Pressure Ranges

PILOT TYPE	OUTLET (CONTROL) PRESSURE RANGE
161AY or 161AYM	15 to 37 mbar (6 to 15-inches w.c.) 0,034 to 0,083 bar (0.5 to 1.2 psig) 0,083 to 0,173 bar (1.2 to 2.5 psig) 0,173 to 0,31 bar (2.5 to 4.5 psig) 0,31 to 0,48 bar (4.5 to 7 psig)
161EB or 161EBM	0,34 to 1,03 bar (5 to 15 psig) 0,69 to 2,76 bar (10 to 40 psig) 2,07 to 5,17 bar (30 to 75 psig) 4,83 to 9,65 bar (70 to 140 psig) 8,96 to 13,8 bar (130 to 200 psig) 13,8 to 24,1 bar (200 to 350 psig)
161EBH or 161EBHM	17,2 to 31,0 bar (250 to 450 psig) ⁽¹⁾ 27,6 to 48,3 bar (400 to 700 psig) ⁽¹⁾

1. The maximum operating pressure for fluoroelastomer pilot diaphragms is limited to 31,0 bar (450 psig).

Table 3. Pilot Pressure Ratings

TYPE	MAXIMUM INLET PRESSURE, bar (PSIG)	MAXIMUM EMERGENCY OUT-LET PRESSURE OR MAXIMUM EMERGENCY SENSE PRESSURE ⁽¹⁾ , bar (PSIG)	MAXIMUM OUTLET PRESSURE, bar (PSIG)	MAXIMUM BLEED (EXHAUST) PRESSURE FOR MONITOR PILOTS, bar (PSIG)	MAXIMUM SENSE (CONTROL) PRESSURE FOR MONITOR PILOTS, bar (PSIG)
161AY	10,3 (150)	10,3 (150)	10,3 (150)	----	----
161EB	103 (1500)	83,7 (1200)	51,7 (750)	----	----
161EBH	103 (1500)	83,7 (1200)	51,7 (750)	----	----
161AYM	10,3 (150)	10,3 (150)	----	10,3 (150)	10,3 (150)
161EBM	103 (1500)	83,7 (1200)	----	103 (1500)	51,7 (750)
161EBHM	130 (1500)	83,7 (1200)	----	103 (1500)	51,7 (750)

1. Maximum pressure to prevent the casings from bursting during abnormal operation (leaking to atmosphere and internal parts damage may occur).

Table 4. Main Valve Minimum Differential Pressures

MAIN VALVE BODY SIZE, DN (INCH)	MAIN SPRING PART NUMBER AND COLOR	MINIMUM DIFFERENTIAL, PERCENT OF CAGE CAPACITY, bar d (PSID)					
		For 90% Capacity			For 100% Capacity		
		100% Trim	60% Trim	30% Trim	100% Trim	60% Trim	30% Trim
25, 50 x 25 (1, 2 x 1)	19B2399X012, White ⁽¹⁾	1,3 (19)	1,3 (19)	1,5 (22)	1,3 (19)	1,4 (20)	1,7 (24)
	19B2400X012, Light Blue	1,9 (28)	1,9 (28)	2,4 (35)	1,9 (28)	1,9 (28)	2,8 (41)
	19B2401X012, Black ⁽²⁾	2,8 (40)	2,8 (41)	3,2 (47)	2,8 (40)	2,9 (42)	4,8 (70)
50 (2)	19B0951X012, Yellow ⁽¹⁾	0,9 (13)	1,2 (17)	1,7 (24)	0,9 (13)	1,2 (17)	1,7 (24)
	18B2126X012, Green	1,1 (16)	1,5 (21)	2,0 (29)	1,4 (20)	1,7 (25)	2,1 (30)
	18B5955X012, Red ⁽²⁾	1,6 (23)	1,9 (28)	2,1 (30)	2,1 (30)	2,1 (31)	2,2 (32)
80 (3)	T14184T0012, Yellow ⁽¹⁾	0,97 (14)	0,97 (14)	1,2 (17)	1,2 (18)	1,2 (18)	1,3 (19)
	19B0781X012, Light Blue	1,0 (15)	1,0 (15)	1,2 (18)	1,4 (21)	1,4 (21)	1,5 (22)
	19B0782X012, Black ⁽²⁾	1,8 (26)	1,8 (26)	1,8 (27)	2,3 (33)	2,3 (33)	2,3 (33)
100 (4)	T14184T0012, Yellow ⁽¹⁾	0,69 (10)	0,76 (11)	0,83 (12)	1,2 (18)	1,4 (20)	1,4 (20)
	18B8501X012, Green	0,9 (14)	0,9 (15)	1,2 (17)	1,5 (22)	1,7 (24)	1,7 (24)
	18B8502X012, Red ⁽²⁾	1,4 (20)	1,7 (24)	2,0 (29)	2,1 (30)	2,1 (30)	2,1 (30)
150, 200 x 150 (6, 8 x 6)	19B0364X012, Yellow ⁽¹⁾	0,6 (8)	0,6 (9)	0,69 (10)	0,69 (10)	0,69 (10)	0,9 (13)
	19B0366X012, Green	1,0 (15)	1,0 (15)	1,1 (16)	1,2 (17)	1,3 (19)	1,4 (20)
	19B0365X012, Red ⁽²⁾	1,1 (16)	1,3 (18)	1,3 (19)	1,4 (20)	1,7 (24)	1,7 (24)

1. The white and yellow springs are only recommended for inlet pressures under 100 psig (6,9 bar).
2. The red and black springs are only recommended for inlet pressures over 500 psig (34,5 bar).

Table 5. Temperature Capabilities

17E67 NITRILE (NBR)	17E68 NITRILE (NBR)	17E97 NITRILE (NBR)	17E88 FLUROELASTOMER (FKM)
0° to 150°F (-17° to 66°C)	-20° to 150°F (-28° to 66°C)	0° to 150°F (-17° to 66°C)	0° to 250°F (-17° to 121°C)

Table 6. Main Valve Maximum Pressures

MAIN SPRING COLOR	BODY SIZE, DN (INCH)	MAXIMUM OPERATING INLET PRESSURE, bar (PSIG)	MAXIMUM OPERATING DIFFERENTIAL PRESSURE, bar (PSIG)	MAXIMUM EMERGENCY INLET AND DIFFERENTIAL PRESSURES ⁽²⁾ , bar d (PSID)
White / Yellow	All	6,9 (100)	6,9 (100)	6,9 (100)
Light Blue / Green	All	34,5 (500)	34,5 (500)	51,7 (750)
Black / Red ⁽¹⁾	All	72,4 (1050)	55,2 (800)	72,4 (1050)
DIAPHRAGM MATERIAL	BODY SIZE, DN (INCH)	MAXIMUM OPERATING INLET PRESSURE, bar (PSIG)	MAXIMUM OPERATING DIFFERENTIAL PRESSURE, bar (PSIG)	MAXIMUM EMERGENCY INLET AND DIFFERENTIAL PRESSURES, bar d (PSID)
17E67 Nitrile	50 (2)	34,5 (500)	34,5 (500)	51,7 (750)
	100 (4)	24,8 (360)	20,7 (300)	51,7 (750)
17E68 Nitrile	25, 50, 50 x 25 (1, 2, 2 x 1)	31,7 (460)	27,5 (400)	31,7 (460)
	80, 100, 150, 200 x 150 (3, 4, 6, 8 x 6)	24,8 (360)	20,7 (300)	34,5 (500)
17E97 Nitrile	All	72,4 (1050)	55,2 (800)	72,4 (1050)
17E88 Fluoroelastomer	All	51,7 (750)	34,5 (500)	51,7 (750)

1. The red and black springs are only recommended for inlet pressures over 34,5 bar (500 psig).
 2. For differential pressures above 27,6 bar d (400 psid) fluoroelastomer diaphragm temperatures are limited to 66°C (150°F).

CAUTION

When using an inlet strainer (key 23), do not use the shim (key 23) and vice versa.

When installing a Type EZR trim package in an existing E-body, make sure flow is up through the center of the cage and down through the cage slots. In some cases, correct flow path is achieved by removing the body from the line and turning it around. If this is done, change the flow arrow to indicate the correct direction. Damage may result if flow is not in the correct direction. After assembly, check the regulator for shutoff and leakage to atmosphere.

Note

It is important that the regulator be installed so that the vent hole in the spring case is unobstructed at all times. For outdoor installations, the regulator should be located away from vehicular traffic and positioned so that water, ice, and other foreign materials cannot enter the spring case through the vent. Avoid placing the regulator beneath eaves or downspouts, and be sure it is above the probable snow level.

Overpressure Protection

The recommended pressure limitations are stamped on the regulator nameplate. Some type of overpressure protection is needed if the actual inlet pressure exceeds the maximum operating outlet pressure rating. Overpressure protection should also be provided if the regulator inlet pressure is greater than the safe working pressure of the downstream equipment.

Regulator operation below the maximum pressure limitations does not preclude the possibility of damage from external sources or debris in the line. The regulator should be inspected for damage after any overpressure condition.

Startup

The regulator is factory set at approximately the midpoint of the spring range or the pressure requested, so an initial adjustment may be required to give the desired results. With proper installation completed and relief valves properly adjusted, slowly open the upstream and downstream shutoff valves.

Adjustment

To change the outlet pressure, remove the closing cap or loosen the locknut and turn the adjusting screw clockwise to increase outlet pressure or counterclockwise to decrease pressure. Monitor the outlet pressure with a test gauge during the adjustment. Replace the closing cap or tighten the locknut to maintain the desired setting.

Taking Out of Service (Shutdown)

WARNING

To avoid personal injury resulting from sudden release of pressure, isolate the regulator from all pressure before attempting disassembly.

CAUTION

Make sure to use a Type EZR bonnet. The Type EZR bonnet is NOT interchangeable with other Fisher E-body bonnets. Installing an improper bonnet can result in stem assembly breakage and unit failure. The bonnet can be identified by the EZR markings on the top.

Type EZR

Main Valve Parts List

Key Description

- 1 Valve Body
- 2 Bonnet Assembly
- 4 Hex Nut
- 5 Top Plug
- 6 O-Ring
- 7 Cage
- 8 Cage O-Ring
- 9 Diaphragm
- 10 O-Ring
- 11 Bottom Plug
- 12 Main Spring
- 13 Flanged Locknut
- 14 Top Plug O-Ring
- 15 Stem
- 16 Backup Ring
- 17 Upper Spring Seat
- 18 O-Ring
- 19 Indicator Fitting
- 20 Indicator Washer
- 21 Indicator Cover
- 22 Indicator Protector
- 23 Inlet Strainer
- 28 O-Ring
- 63 Pilot Supply Pipe Plug
- 64 Bonnet Pipe Plug
- 66 O-Ring
- 67 O-Ring
- 70 O-Ring
- 71 Restrictor Plate
- 72 E-Ring
- 79 Washer
- 83 Machine Screw
- 121 O-Ring
- 126 Cap Screw
- 129 Socket Head Screw
- 130 Lock Washer

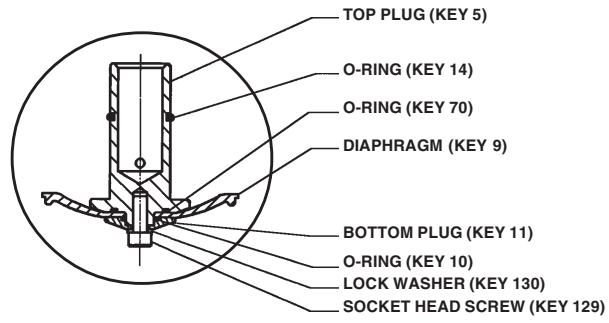

DN 25 AND 50 X 25 (1 AND 2 X 1-INCH)
 DIAPHRAGM ASSEMBLY

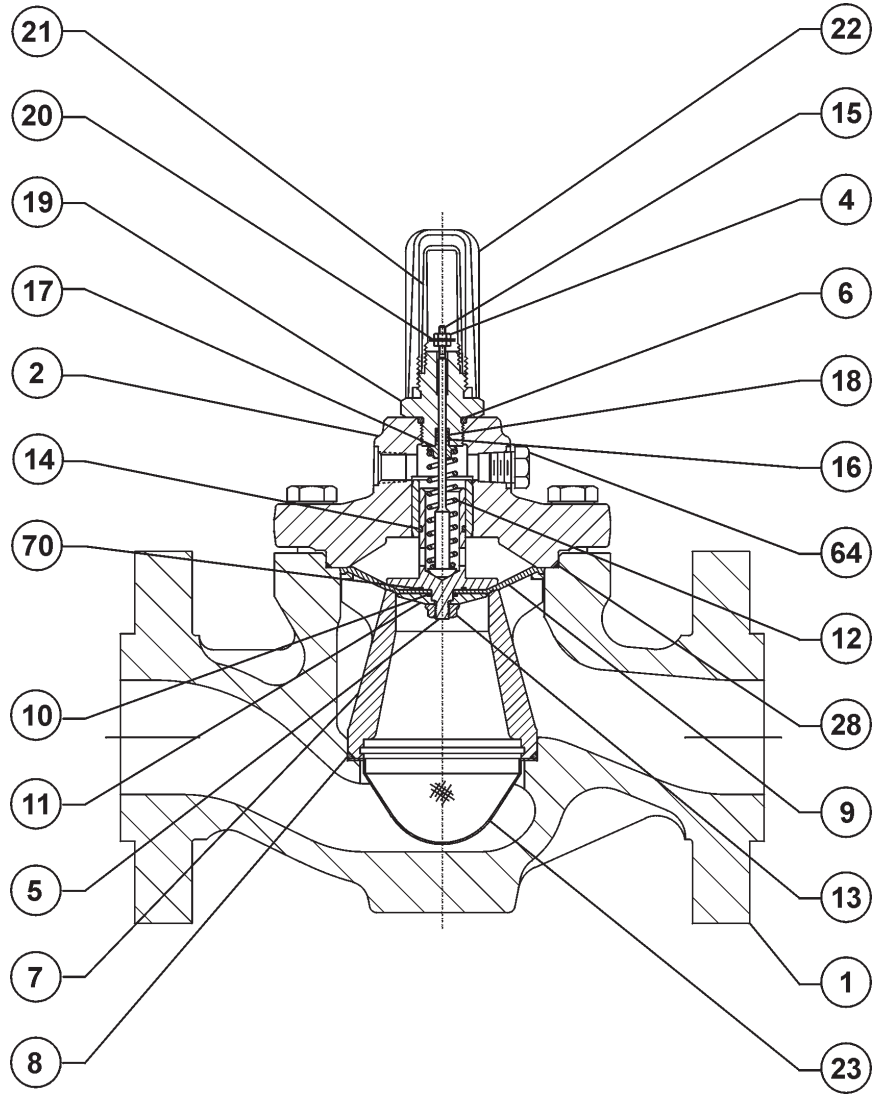

MAIN VALVE ASSEMBLY

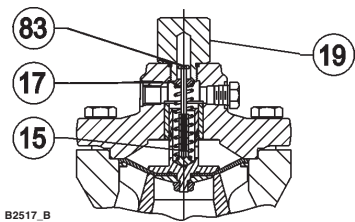

DN 50 (2-INCH) BODY SIZE

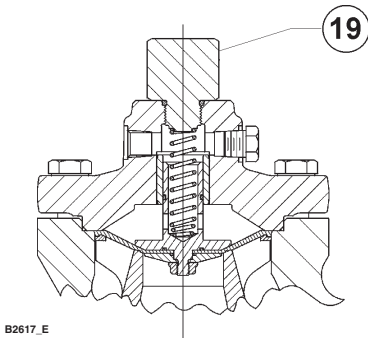

DN 25, 5- x 25, 80, 100, 150
 (1, 2 x 1, 3, 4, AND 6-INCH) BODY SIZES

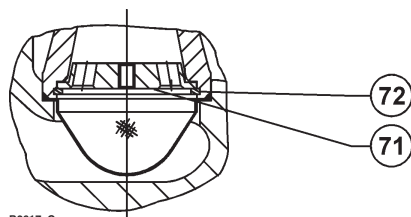

RESTRICTED TRIM

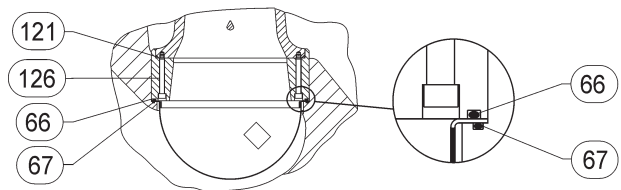

8 X 6-INCH RESTRICTOR PLATE O-RING PLACEMENT

Figure 1. Type EZR Main Valve Assembly

161EB Series Parts List

Key Description

- 1 Body Assembly
- 2 Spring Case
- 3 Body Plug
- 4 Valve Plug
- 6 Plug Spring
- 7 Diaphragm Assembly
- 8 Control Spring Seat
- 9 Control Spring
- 10 Diaphragm Limiter
- 11 Adjusting Screw
- 12 Locknut
- 13 Machine Screw
- 14 Pipe Plug
- 15 Body Plug O-Ring
- 16 Closing Cap
- 17 Closing Cap Gasket
- 18 Y602-12 Vent Assembly
- 19 Stem Guide Seal Assembly

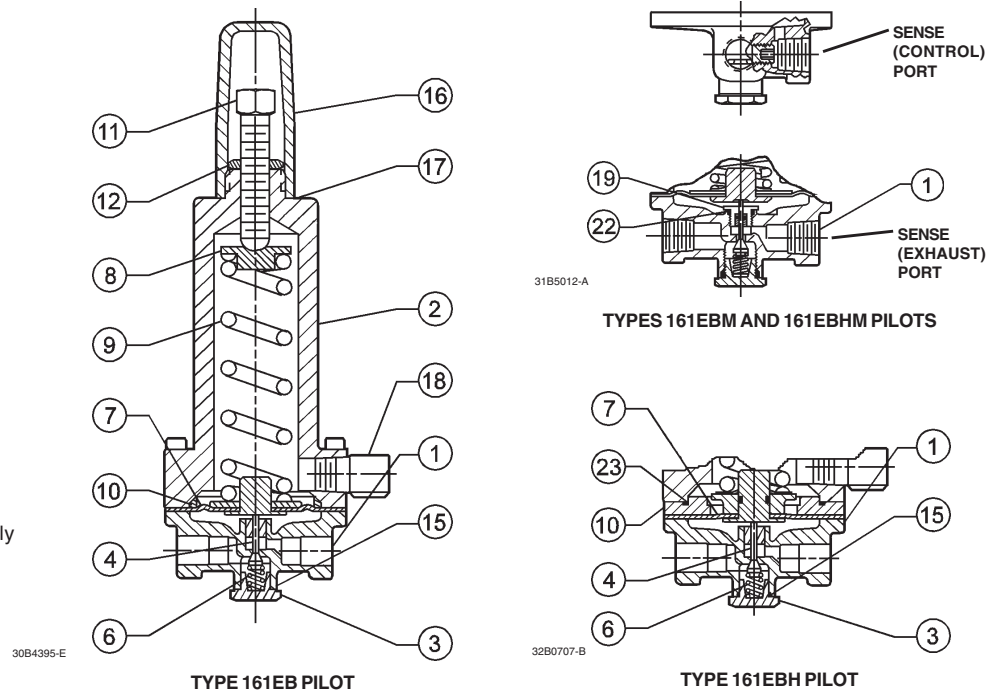

Figure 2. 161EB Series Assemblies

Types 161AY and 161AYM Parts List

Key Description

- 1 Body
- 2 Cap Screw
- 3 Spring Case Assembly
- 4 Lower Casing
- 6 Orifice
- 7 Diaphragm Head
- 8 Pusher Post
- 10 Diaphragm
- 11 Body Seal
- 12 Insert Seal
- 13 Disk Assembly
- 14 Stem
- 15 Cotter Pin
- 16 Lever Assembly
- 17 Machine Screws
- 18 Guide Insert
- 21 Hex Nut
- 22 Closing Cap
- 23 Hex Nut
- 24 Cap Screw
- 25 Closing Cap
- 26 Vent Assembly
- 27 Pipe Plug
- 30 Stem Seal O-Ring
- 31 Throat Seal
- 33 Machine Screw
- 35 Adjusting Screw
- 37 Spring Holder
- 38 Machine Screw
- 39 Overpressure Spring
- 40 Pusher Post Connector
- 46 Nameplate
- 47 Drive Screw
- 48 Post Seal
- 49 Connector Seal
- 50 Backup Ring
- 55 Restriction
- 56 Baffle Plate

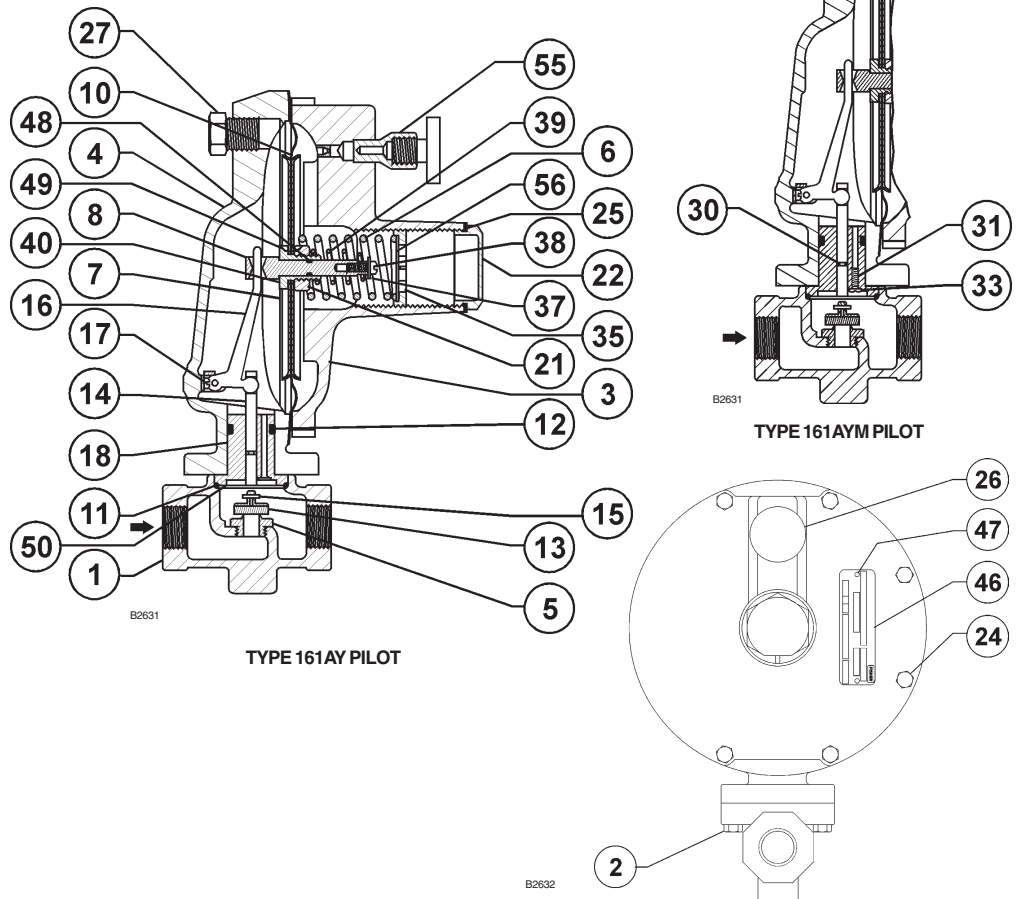

Figure 3. Types 161AY and 161AYM Assemblies

Type EZR

Type 112 Restrictor Parts List

Key Description

- 14 Pipe Plug
- 21 Body
- 22 Groove Valve
- 23 Retainer
- 24 Groove Valve O-Ring

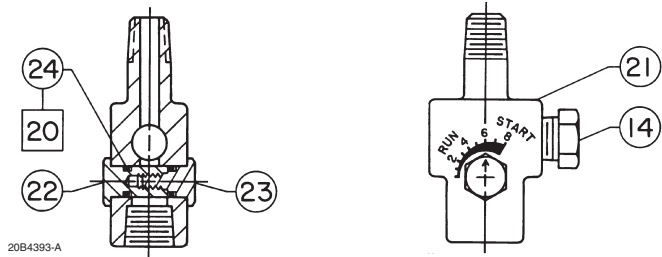

Figure 4. Type 112 Assembly

Type 252 Filter Parts List

Key Description

- 1 Filter Head Assembly
- 2 Filter Body
- 3 Lower Seat
- 4 Filter Cartridge
- 5 O-Ring
- 6 Pipe Plug
- 7 Drain Valve (Optional)
- 8 Upper Seat

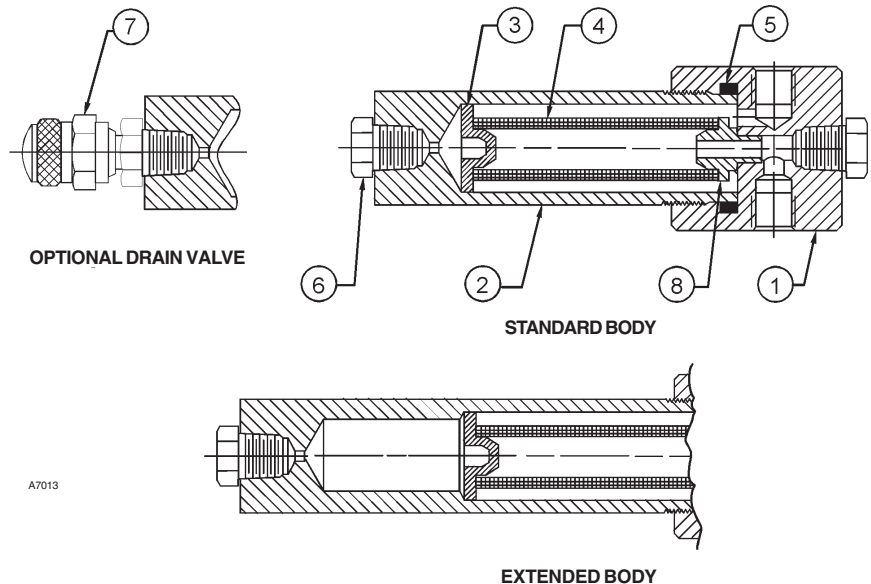

Figure 5. Type 252 Assembly

©Fisher Controls International, Inc., 2002; All Rights Reserved

Fisher and Fisher Regulators are marks owned by Fisher Controls International, Inc. The Emerson logo is a trade mark and service mark of Emerson Electric Co. All other marks are the property of their respective owners.

The contents of this publication are presented for informational purposes only, and while every effort has been made to ensure their accuracy, they are not to be construed as warranties or guarantees, express or implied, regarding the products or services described herein or their use or applicability. We reserve the right to modify or improve the designs or specifications of such products at any time without notice.

For information, contact Fisher Controls, International:

Within USA (800) 588-5853 – Outside USA (972) 542-0132

Italy – (39) 051-4190-606

Singapore – (65) 770-8320

Mexico – (52) 57-28-0888

Printed in U.S.A.

www.FISHERregulators.com

