

Introduction

This installation guide provides instructions for installation, startup and adjustment. To receive a copy of the instruction manual, contact your local Sales Office or view a copy at www.fisherregulators.com. For further information refer to: Type LR128 Instruction Manual, D103578X012.

P.E.D. Categories

This product may be used as a pressure accessory with pressure equipment in the following Pressure Equipment Directive 97/23/EC categories.

PRODUCT SIZE	CATEGORY	FLUID TYPE
DN 25 and 50 / 1 and 2 in.	SEP	Liquid
DN 80 and 100 / 3 and 4 in.	II	Liquid

Specifications

Main Valve Body Sizes, End Connection Styles and Body Ratings⁽¹⁾

See Table 1

Maximum Control Pressure⁽¹⁾

See Tables 1, 2 and 5

Minimum Set Pressure⁽¹⁾

1.7 bar / 25 psig

Set Pressure or Backpressure Control Ranges⁽¹⁾

See Table 4

Temperature Capabilities⁽¹⁾

See Table 3

Installation

WARNING

Only qualified personnel shall install or service a relief valve or backpressure regulator. Relief valve or backpressure regulator should be installed, operated and maintained in accordance with international and applicable codes and regulations and Emerson Process Management Regulator Technologies, Inc. (Emerson™) instructions.

If using a relief valve or backpressure regulator on a hazardous or flammable fluid service, personal injury and property damage could occur due to fire or explosion of vented fluid that may have accumulated. To prevent

such injury or damage, provide piping or tubing to vent the fluid to a safe, well-ventilated area or containment vessel. Also, when venting a hazardous fluid, the piping or tubing should be located far enough away from any buildings or windows so to not create a further hazard and the vent opening should be protected against anything that could clog it.

Personal injury, equipment damage or leakage due to escaping fluid or bursting of pressure-containing parts may result if this relief valve or backpressure regulator is overpressured or is installed where service conditions could exceed the limits given in the Specifications section or where conditions exceed any ratings of the adjacent piping or piping connections.

To avoid such injury or damage, provide pressure-relieving or pressure-limiting devices (as required by the appropriate code, regulation or standard) to prevent service conditions from exceeding limits.

Additionally, physical damage to the relief valve or backpressure regulator could result in personal injury and property damage due to escaping fluid. To avoid such injury and damage, install the relief valve or backpressure regulator in a safe location.

Clean out all pipelines before installation of the relief valve or backpressure regulator and check to be sure the relief valve or backpressure regulator has not been damaged or has collected foreign material during shipping. For NPT bodies, apply pipe compound to the external pipe threads. For flanged bodies, use suitable line gaskets and approved piping and bolting practices. Install the relief valve or backpressure regulator in any position desired, unless otherwise specified, but be sure flow through the body is in the direction indicated by the arrow on the body.

1. The pressure/temperature limits in this Installation Guide and any applicable standard or code limitation should not be exceeded.

Type LR128

Table 1. Type LR128 Main Valve Body Sizes, End Connection Styles, Structural Design Ratings and Maximum Operating Inlet Pressures⁽¹⁾

MAIN VALVE BODY SIZE		MAIN VALVE BODY MATERIAL	END CONNECTION STYLE ⁽²⁾	STRUCTURAL DESIGN RATING ⁽³⁾		MAXIMUM OPERATING RELIEF (INLET) PRESSURE INCLUDING BUILD-UP ⁽³⁾		MAXIMUM OPERATING OUTLET PRESSURE	
DN	In.			bar	psig	bar	psig	bar	psig
25, 50, 80 and 100	1, 2, 3 and 4	WCC Steel	NPT or SWE (1 and 2 in. only)	103	1500	31.0	450	31.0	450
			CL150 RF	20.0	290	20.0	290	20.0	290
			CL300 RF	51.7	750	31.0	450	31.0	450
			CL600 RF	103	1500				
			PN 16/25/40 RF	40.0	580				
		CF8M Stainless steel	NPT (1 and 2 in. only)	99.2	1440	31.0	450	31.0	450
			CL150 RF	19.0	275	31.0	450	31.0	450
			CL300 RF	49.6	720				
			CL600 RF	99.2	1440				
			PN 16/25/40 RF	40.0	580				

1. The pressure/temperature limits in this Installation Guide and any applicable standard or code limitation should not be exceeded.
2. Ratings and end connections for other than ASME standard can usually be provided. Contact your local Sales Office for assistance.
3. Maximum cold working pressure (CWP) per ASME B16.34 or product bulletin limit, whichever is lowest. Temperature may decrease these maximum pressures.

Table 2. Type MR98H Pilot Maximum Cold Working Pressure^{(1)/(2)}

BODY SIZE	BODY AND SPRING CASE MATERIAL	MAXIMUM INLET PRESSURE	MAXIMUM OUTLET PRESSURE
1/2 NPT	Steel or Stainless steel	31.0 bar / 450 psig	31.0 bar / 450 psig

1. The pressure/temperature limits in this Installation Guide and any applicable standard or code limitation should not be exceeded.
2. Temperature and/or the body end connection may decrease these maximum pressures.

Note

It is important that the relief valve or backpressure regulator be installed so that the vent hole in the spring case is unobstructed at all times. For outdoor installations, the relief valve or backpressure regulator should be located away from vehicular traffic and positioned so that water, ice and other foreign materials cannot enter the spring case through the vent. Avoid placing the relief valve or backpressure regulator beneath eaves or downspouts and be sure it is above the probable snow level.



CAUTION

When installing Type LR128 trim in an existing Fisher® E-body, damage can result if flow is not in the correct direction. Look at the body web to confirm that flow is in the correct direction—up through the center of the cage and down through the cage slots. Change the existing flow arrow if necessary.

Overpressure

Maximum inlet pressures depend upon body materials and temperatures. Refer to the nameplate for the maximum inlet pressure of the relief valve or backpressure regulator. The relief valve or backpressure regulator should be inspected for damage after any overpressure condition. **Fisher relief valve or backpressure regulators are NOT ASME safety relief valves.**

Startup

The relief valve or backpressure regulator is factory set at approximately the midpoint of the spring range or the pressure requested, so an initial adjustment may be required to give the desired results. With proper installation completed and relief valves properly adjusted, slowly open the upstream and downstream shutoff valves (if applicable).

Adjustment

To change the outlet pressure, remove closing cap or loosen the locknut and turn the adjusting screw clockwise to increase outlet pressure or counterclockwise to decrease pressure. Monitor the outlet pressure with a test gauge during the adjustment. Replace closing cap or tighten the locknut to maintain the desired setting.

Taking Out of Service (Shutdown)



WARNING

To avoid personal injury resulting from sudden release of pressure, isolate the relief valve or backpressure regulator from all pressure before attempting disassembly.

If pressure is introduced first to the main valve before the pilot, the main valve may go wide-open and subject the downstream system to full inlet pressure.

Parts List

Type LR128 Main Valve

Key	Description
1	Valve Body
2	Bonnet Assembly
3	Cap Screw
4	Hex Nut
5	Top Plug
6*	O-ring
7	Cage
8*	Cage O-ring
9*	Diaphragm
10	O-ring
11	Bottom Plug
12	Main Valve Spring
14*	Top Plug O-ring
13	Flanged Hex Nut
15	Stem
16*	Back-up Ring
17	Upper Spring Seat
18*	O-ring
19	Indicator Fitting
20	Indicator Washer
21	Indicator Cover
22	Indicator Protector
23	Inlet Strainer
24	Nameplate
25	Flow Arrow
26	Drive Screw
28*	O-ring
63	Pipe Plug
70*	O-ring
129	Socket Head Screw
130	Lock Washer

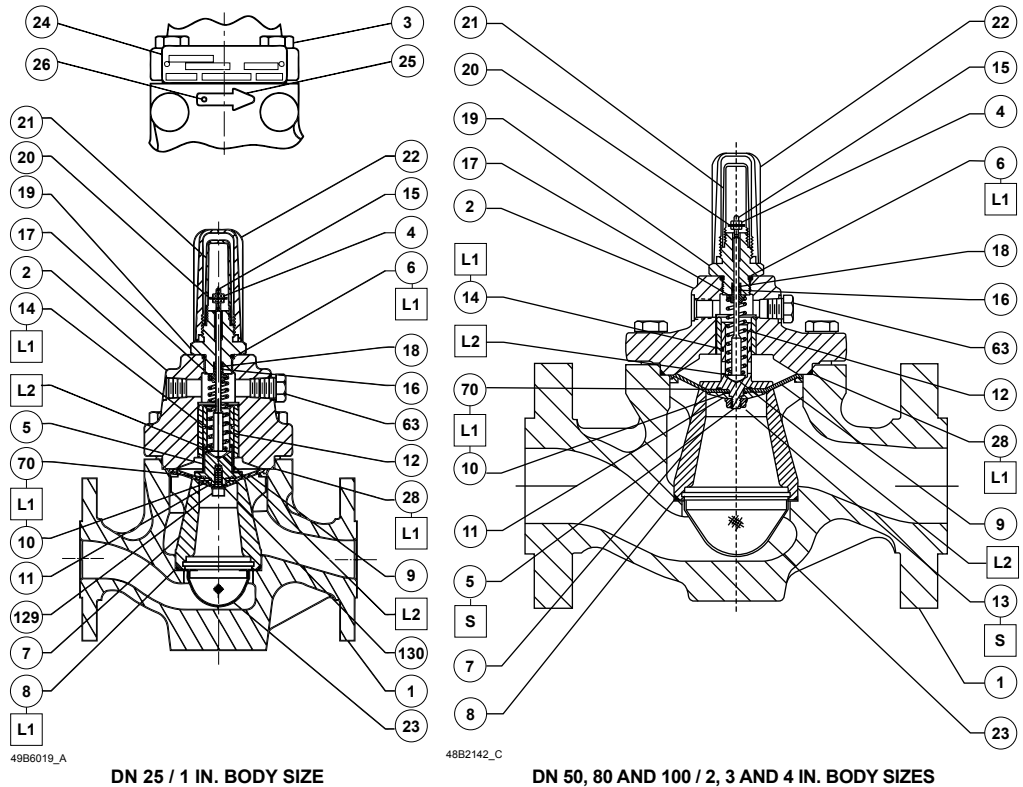

□ APPLY LUBRICANT / SEALANT⁽¹⁾:
 L1 = LITHIUM POLYMER TYPE LUBRICANT (MULTI-PURPOSE GREASE)
 L2 = ANTI-SEIZE LUBRICANT
 S = MEDIUM STRENGTH THREADLOCKER

1. Lubricants and sealant must be selected such that they meet the temperature requirements.

Figure 1. Type LR128 Main Valve Assembly

Type MR98H Pilot

Key	Description
1	Regulator Body
2	Spring Case
3*	Orifice
4*	Valve Plug
5	Bottom Plug
7	Valve Plug Guide
8	Lower Spring Seat
9	Upper Spring Seat
10	Pusher Post
11	Regulator Spring
12*	Diaphragm
15	Adjusting Screw
16	Cap Screw
17	Jam Nut
28	Lock Washer
29*	Gasket
31	Locknut
58	Washer
63*	Bottom Seal Plug

*Recommended spare part

GF04916

□ APPLY LUBRICANT / SEALANT⁽¹⁾:
 L1 = GENERAL PURPOSE PTFE OR LITHIUM GREASE FOR O-RINGS
 L2 = ANTI - SEIZE COMPOUND
 L4 = GRAPHITE SEALANT FOR GRAPHITE RING

1. Lubricants and sealants must be selected such that they meet the temperature requirements.
 2. Apply L2 (anti-seize compound) on key 16 for stainless steel bolts.
 3. Apply L4 (graphite sealant) instead of L1 (general purpose PTFE or lithium grease) on key 63 for graphite ring.

Figure 2. Type MR98H Pilot Assembly

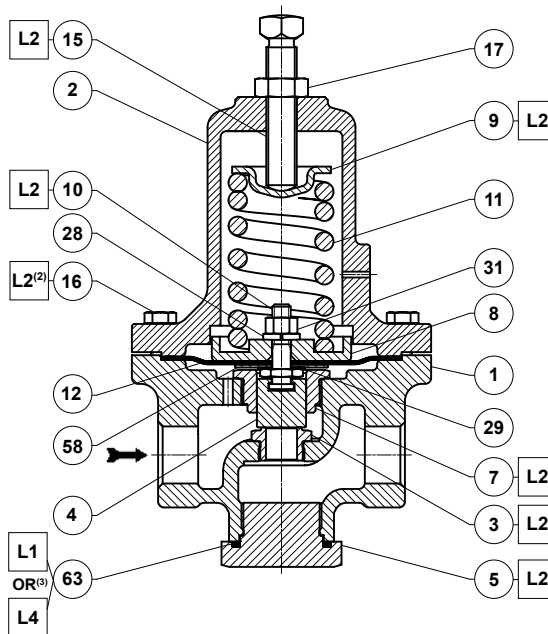

Type LR128

Table 3. Temperature Capabilities

17E68 NITRILE (NBR) (STANDARD)	17E97 NITRILE (NBR)	17E88 FLUOROCARBON (FKM)
-29 to 66°C / -20 to 150°F	-18 to 66°C / 0 to 150°F	-18 to 121°C / 0 to 250°F ⁽¹⁾

1. Fluorocarbon (FKM) is limited to 93°C / 200°F in hot water.

Table 4. Relief Set Pressure or Backpressure Control Ranges

PILOT	SET PRESSURE RANGE		SPRING WIRE DIAMETER		SPRING FREE LENGTH		SPRING PART NUMBER AND COLOR
	bar	psig	mm	In.	mm	In.	
Type MR98H	1.7 to 5.2	25 to 75	5.94	0.234	65.9	2.595	ERAA01910A0, Green
	4.8 to 9.7	70 to 140	7.19	0.283	62.0	2.44	ERAA01911A0, Red
	9.0 to 13.8	130 to 200	8.41	0.331	57.2	2.250	ERAA02889A0, Blue
	10.3 to 25.9 ⁽¹⁾	150 to 375 ⁽¹⁾	10.0	0.394	129	5.063	1N943427142, Unpainted

1. 150 to 375 psig / 10.3 to 25.9 bar spring range is for the Type MR98HH pilot construction.

Table 5. Type LR128 Maximum Pressure Ratings and Diaphragm Selection Information⁽¹⁾

BODY SIZE		DIAPHRAGM MATERIAL	MAXIMUM OPERATING INLET PRESSURE ⁽³⁾		MAXIMUM OPERATING DIFFERENTIAL PRESSURE ⁽³⁾		MAXIMUM EMERGENCY INLET AND DIFFERENTIAL PRESSURE		DIAPHRAGM STYLE
			bar	psig	bar d	psid	bar d	psid	
25	1	17E68 Nitrile (NBR), Low temperature	31.0	450	27.6	400	31.0	450	130
		17E97 Nitrile (NBR), High-pressure and/or erosion resistance	31.0	450	31.0 ⁽²⁾	450 ⁽²⁾	31.0	450	
		17E88 Fluorocarbon (FKM), High aromatic hydrocarbon content resistance	31.0	450	31.0 ⁽²⁾	450 ⁽²⁾	31.0	450	
50	2	17E68 Nitrile (NBR), Low temperature	31.0	450	27.6	400	31.0	450	
		17E97 Nitrile (NBR), High-pressure and/or erosion resistance	31.0	450	31.0 ⁽²⁾	450 ⁽²⁾	31.0	450	
		17E88 Fluorocarbon (FKM), High aromatic hydrocarbon content resistance	31.0	450	31.0 ⁽²⁾	450 ⁽²⁾	31.0	450	
80	3	17E68 Nitrile (NBR), Low temperature	24.8	360	20.7	300	31.0	450	
		17E97 Nitrile (NBR), High-pressure and/or erosion resistance	31.0	450	31.0 ⁽²⁾	450 ⁽²⁾	31.0	450	
		17E88 Fluorocarbon (FKM), High aromatic hydrocarbon content resistance	31.0	450	31.0 ⁽²⁾	450 ⁽²⁾	31.0	450	
100	4	17E68 Nitrile (NBR), Low temperature	24.8	360	20.7	300	31.0	450	
		17E97 Nitrile (NBR), High-pressure and/or erosion resistance	31.0	450	31.0 ⁽²⁾	450 ⁽²⁾	31.0	450	
		17E88 Fluorocarbon (FKM), High aromatic hydrocarbon content resistance	31.0	450	31.0 ⁽²⁾	450 ⁽²⁾	31.0	450	

1. See Table 1 for main valve structural design ratings and Table 4 for pilot ratings.

2. For differential pressure above 27.6 bar d / 400 psid diaphragm temperatures are limited to 66°C / 150°F.

3. These are recommendations that provide the best regulator performance for a typical application. Please contact your local Sales Office for further information if a deviation from the standard recommendations are required.

Industrial Regulators

Emerson Process Management Regulator Technologies, Inc.

USA - Headquarters
McKinney, Texas 75070 USA
Tel: +1 800 558 5853
Outside U.S. +1 972 548 3574

Asia-Pacific
Shanghai 201206, China
Tel: +86 21 2892 9000

Europe
Bologna 40013, Italy
Tel: +39 051 419 0611

Middle East and Africa
Dubai, United Arab Emirates
Tel: +971 4811 8100

Natural Gas Technologies

Emerson Process Management Regulator Technologies, Inc.

USA - Headquarters
McKinney, Texas 75070 USA
Tel: +1 800 558 5853
Outside U.S. +1 972 548 3574

Asia-Pacific
Singapore 128461, Singapore
Tel: +65 6770 8337

Europe
Bologna 40013, Italy
Tel: +39 051 419 0611
Chartres 28008, France
Tel: +33 2 37 33 47 00

Middle East and Africa
Dubai, United Arab Emirates
Tel: +971 4811 8100

TESCOM

Emerson Process Management Tescom Corporation

USA - Headquarters
Elk River, Minnesota 55330-2445, USA
Tels: +1 763 241 3238
+1 800 447 1250

Europe
Selmsdorf 23923, Germany
Tel: +49 38823 31 287

Asia-Pacific
Shanghai 201206, China
Tel: +86 21 2892 9499

For further information visit www.fisherregulators.com

The Emerson logo is a trademark and service mark of Emerson Electric Co. All other marks are the property of their prospective owners. Fisher is a mark owned by Fisher Controls International LLC, a business of Emerson Process Management.

The contents of this publication are presented for informational purposes only, and while every effort has been made to ensure their accuracy, they are not to be construed as warranties or guarantees, express or implied, regarding the products or services described herein or their use or applicability. We reserve the right to modify or improve the designs or specifications of such products at any time without notice.

Emerson Process Management Regulator Technologies, Inc. does not assume responsibility for the selection, use or maintenance of any product. Responsibility for proper selection, use and maintenance of any Emerson Process Management Regulator Technologies, Inc. product remains solely with the purchaser.



EMERSON
Process Management