

## Introduction

This installation guide provides instructions for installation, startup and adjustment. To receive a copy of the instruction manual, contact your local Sales Office or view a copy at [www.fisherregulators.com](http://www.fisherregulators.com). For further information refer to Type MR105 Instruction Manual, Form 5874, D103246X012.

## P.E.D. Category

This product may be used as a pressure accessory with pressure equipment in the following Pressure Equipment Directive 97/23/EC categories. It may also be used outside of the Pressure Equipment Directive using sound engineering practice (SEP) per table below.

PRODUCT SIZE	CATEGORY
DN 25 / NPS 1	SEP
DN 50 / NPS 2	II
DN 80 / NPS 3	II
DN 100 / NPS 4	II

## Specifications

### Available Constructions

**Type MR105 with low-pressure actuator:** Direct-operated large multi-purpose regulator with 0.34 to 3.0 bar / 5 to 43 psig pressure range

**Type MR105 with high-pressure actuator:** Direct-operated large multi-purpose regulator with 1.7 to 20.7 bar / 25 to 300 psig pressure range

### Body Sizes and End Connection Styles

**DN 25 and 50 / NPS 1 and 2:** NPT, CL125 FF, CL250 RF, CL150 RF, CL300 RF, CL600 RF and PN 16/25/40 RF

**DN 80 and 100 / NPS 3 and 4:** CL125 FF, CL250 RF, CL150 RF, CL300 RF, CL600 RF and PN 16 RF

### Maximum Inlet Pressures<sup>(1)</sup>

**Low-Pressure Actuator:** 27.6 bar / 400 psig

**High-Pressure Actuator:** 27.6 bar / 400 psig

### Maximum Outlet Pressures<sup>(1)</sup>

**Low-Pressure Actuator:** 4.8 bar / 70 psig

**High-Pressure Actuator<sup>(2)</sup>:** 27.6 bar / 400 psig

### Maximum Emergency Casing Pressures<sup>(1)</sup>

**Low-Pressure Actuator:** 4.8 bar / 70 psig

**High-Pressure Actuator<sup>(2)</sup>:** 27.6 bar / 400 psig

### Maximum Setpoint<sup>(1)</sup>

**Low-Pressure Actuator:** 3.0 bar / 43 psig

**High-Pressure Actuator:**

**Nitrile (NBR) and Ethylene Propylene (EPDM)**

**Diaphragm:** 20.7 bar / 300 psig

**Fluorocarbon (FKM) Diaphragm:** 10.3 bar / 150 psig

### Outlet Pressure Ranges<sup>(1)</sup>

**DN 25 and 50 / NPS 1 and 2:**

**Low-Pressure Actuator:** 0.34 to 0.83 bar / 5 to 12 psig;

0.69 to 1.6 bar / 10 to 24 psig; 0.96 to 2.2 bar /

14 to 32 psig; 1.2 to 3.0 bar / 18 to 43 psig

**High-Pressure Actuator:** 1.7 to 4.1 bar / 25 to

60 psig<sup>(3)</sup>; 3.0 to 6.9 bar / 43 to 100 psig; 5.2 to 12.1 bar /

75 to 175 psig<sup>(4)</sup>; 7.6 to 20.7 bar / 110 to 300 psig<sup>(4)</sup>

**DN 80 and 100 / NPS 3 and 4:**

**Low-Pressure Actuator:** 0.34 to 0.55 bar / 5 to 8 psig;

0.55 to 1.4 bar / 8 to 20 psig; 0.83 to 2.1 bar / 12 to 30 psig;

1.2 to 2.7 bar / 18 to 39 psig

**High-Pressure Actuator:** 2.7 to 5.0 bar / 39 to 72 psig;

4.9 to 12.1 bar / 71 to 175 psig<sup>(4)</sup>; 7.6 to 17.2 bar /

110 to 250 psig<sup>(4)</sup>

### Temperature Capabilities<sup>(1)</sup>

**Nitrile (NBR):** -29 to 82°C / -20 to 180°F

**Fluorocarbon (FKM)<sup>(5)</sup>:** -7 to 121°C / 20 to 250°F

**Ethylene Propylene (EPDM)<sup>(6)</sup>:** -29 to 107°C /

-20 to 225°F

### Maximum Differential Pressures<sup>(1)</sup>

#### Liquid Application:

**Low-Pressure Actuator:**

*DN 25 and 50 / NPS 1 and 2:* 13.6 bar / 200 psig

*DN 80 and 100 / NPS 3 and 4:* 15.5 bar / 225 psig

**High-Pressure Actuator:**

*DN 25 / NPS 1:* 17.2 bar / 250 psig

*DN 50 / NPS 2:* 13.6 bar / 200 psig

*DN 80 / NPS 3:* 15.5 bar / 225 psig

*DN 100 / NPS 4:* 17.2 bar / 250 psig

#### Other Applications:

**Low-Pressure Actuator:** 27.6 bar / 400 psig or maximum inlet pressure, whichever is lower

**High-Pressure Actuator:** 27.6 bar / 400 psig or maximum inlet pressure, whichever is lower

### Maximum Pressures over Set Pressure to Avoid Internal Parts Damage<sup>(1)</sup>

**Low-Pressure Actuator:** 1.4 bar / 20 psig

**High-Pressure Actuator:** 8.3 bar / 120 psig

1. The pressure/temperature limits in this Installation Guide or any applicable limitation should not be exceeded.

2. Maximum Outlet and Emergency Casing Pressures for constructions with Fluorocarbon (FKM) diaphragm are limited to 15.8 bar / 230 psig or the body rating limit, whichever is lower.

3. DN 50 / NPS 2 body size spring range is limited up to 3.1 bar / 45 psig only.

4. Maximum setpoint is limited to 10.3 bar / 150 psig for constructions with Fluorocarbon (FKM) diaphragm.

5. Fluorocarbon (FKM) is limited to 93°C / 200°F hot water.

6. Ethylene Propylene (EPDM) is limited to -7 to 121°C / 20 to 250°F when used with Low Pressure Actuator.



# Type MR105

## Installation



**WARNING**

Only qualified personnel should install or service a regulator. Regulators should be installed, operated and maintained in accordance with international and applicable codes and regulations and Emerson Process Management Regulator Technologies, Inc. instructions.

If the regulator vents fluid or a leak develops in the system, it indicates that service is required. Failure to take the regulator out of service immediately may create a hazardous condition.

Personal injury, equipment damage or leakage due to escaping fluid or bursting of pressure-containing parts may result if this regulator is overpressured or is installed where service conditions could exceed the limits given in the Specifications section or where conditions exceed any ratings of the adjacent piping or piping connections.

To avoid such injury or damage, provide pressure-relieving or pressure-limiting devices (as required by the appropriate code, regulation or standard) to prevent service conditions from exceeding limits.

Additionally, physical damage to the regulator could result in personal injury and property damage due to escaping fluid. To avoid such injury and damage, install the regulator in a safe location.

Clean out all pipelines before installation of the regulator and check to be sure the regulator has not been damaged or has collected foreign material during shipping. For NPT bodies, apply pipe compound to the external pipe threads. For flanged bodies, use suitable line gaskets and approved piping and bolting practices.

Vertical installation with the actuator oriented up or down is recommended. The unit will operate in horizontal installation with actuator on the side, however, this could result in premature wear of parts. Make sure that flow will be in the same direction as that indicated by the body arrow. Orientation of the two vents should always be down. Vents may be rotated after regulator installation so that the vent screens are down.

A control line must be installed to allow outlet pressure to register on the actuator's diaphragm. It should be installed four to eight pipe diameters downstream of the regulator and in an area of pipe that is free of turbulence.

### Note

**It is important that the regulator be installed so that the vent hole in the spring case is unobstructed at all times. For outdoor installations, the regulator should be located away from vehicular traffic and positioned so that water, ice and other foreign materials cannot enter the spring**

**case through the vent. Avoid placing the regulator beneath eaves or downspouts and be sure it is above the probable snow level.**

## Overpressure Protection

The recommended pressure limitations are stamped on the regulator nameplate. Some type of overpressure protection is needed if the actual inlet pressure exceeds the maximum operating outlet pressure rating. Overpressure protection should also be provided if the regulator inlet pressure is greater than the safe working pressure of the downstream equipment.

Regulator operation below the maximum pressure limitations does not preclude the possibility of damage from external sources or debris in the line. The regulator should be inspected for damage after any overpressure condition.

## Startup

The regulator is set at the factory for the setpoint specified on the order or at the midpoint of the spring range. The allowable spring range is stamped on the nameplate. If a pressure setting other than specified is desired, be sure to change the pressure setting by following the Adjustment section. With proper installation completed and relief valves properly adjusted, slowly open the upstream and downstream shutoff valves (if applicable).

## Adjustment

To change the outlet pressure, loosen the locknut and turn the adjusting screw clockwise to increase pressure or counterclockwise to decrease pressure. Monitor the outlet pressure with a test gauge during the adjustment. Tighten the locknut to maintain the desired setting.

## Taking Out of Service (Shutdown)



**WARNING**

**To avoid personal injury resulting from sudden release of pressure, isolate the regulator from all pressure before attempting disassembly.**

## Parts List

Key	Description
1	Valve Body
2	Body Flange
3	Stud Bolt DN 25 / NPS 1 (4 required) DN 50, 80 and 100 / NPS 2, 3 and 4 (8 required)
4	Gasket
5	Lower Indicator Fitting
6	O-ring Retainer
7	Indicator O-ring
8	Hex Nut
9	Valve Spring
10	Indicator Stem

## Parts List (continued)

Key	Description
11	Cage
12	Port Seal
13	Seat Ring
14	Piston Ring
15	Upper Seal
16	Valve Plug
17	Cage O-ring
18	Travel Indicator Scale
19	Travel Indicator Protector
20	Valve Plug O-ring
21	Lower Indicator Fitting O-ring
22	Flange Nut
23	E-Ring
24	Drive Screw (6 required)
25	Flow Arrow
26	Vent (2 required/ 1 required for Pressure-Loaded Actuator)
27	Plug
28	Spring Seat
29	Hex Nut DN 25 / NPS 1 (4 required) DN 50, 80 and 100 / NPS 2, 3 and 4 (8 required)
30	Pipe Plug
33	NACE Tag (not shown)
34	Seal Wire (not shown)
35	Indicator Fitting
36	Back O-ring (2 required)
37	Indicator Fitting O-ring
38	Pipe Plug
40	Actuator Stem
43	Nameplate
44	Lube Fitting
45	Wiper Ring
46	Bearing (2 required)
47	Valve Stem O-ring (2 required)
48	Jam Nut (2 required)
49	Spring Washer
51	Lower Diaphragm Head O-ring
52	Lower Spring Guide
53	Lower Diaphragm Head
54	Lower Spring Seat
55	Diaphragm Plate
56	Diaphragm
57	Cap Screw
58	Hex Nut Low-Pressure Actuator (16 required) High-Pressure Actuator (8 required)
60	O-ring
61	Bonnet
62	Lower Diaphragm Casing
63	Upper Diaphragm Casing
64	Upper Diaphragm Casing O-ring
65	Cap Screw (10 required)
66	Spring Case Spacer
67	Cap Screw (6 required)
68	Control Spring
69	Upper Spring Seat
70	Spring Case
71	Seal Washer (not shown)
72	Jam Nut
73	Adjusting Screw
75	Restrictor (not shown)
76	Pipe Bushing
81	Pipe Nipple (not shown)
82	Drain Valve (not shown)
84	Internal Stiffener Plate
85	Bleed Valve (not shown)
87	Upper Casing Welding Assembly (not shown)

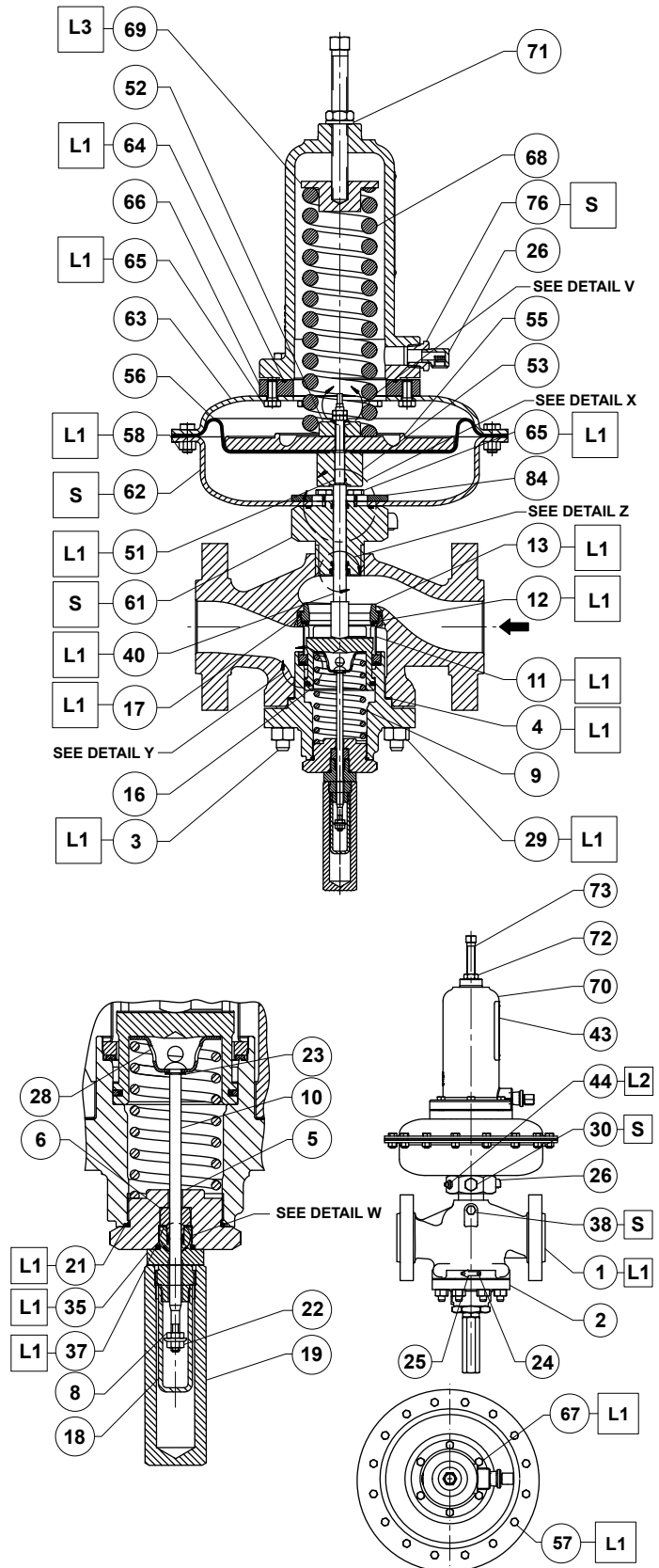

GE38435

□ APPLY LUBRICANT OR SEALANT<sup>(1)</sup>:  
 L1 = MULTI-PURPOSE POLYTETRAFLUOROETHYLENE (PTFE) LUBRICANT  
 L2 = MULTI-PURPOSE NLGI<sup>(2)</sup> GRADE 1 GREASE  
 L3 = ANTI-SEIZE COMPOUND  
 S = MULTI-PURPOSE PTFE THREAD SEALANT

Note: Keys 64 and 71 are used only for pressure-loaded actuators.

1. Lubricants and sealants must be selected such that they meet the temperature requirements.
2. National Lubricating Grease Institute.

Figure 1. Type MR105 Assembly Drawings

# Type MR105

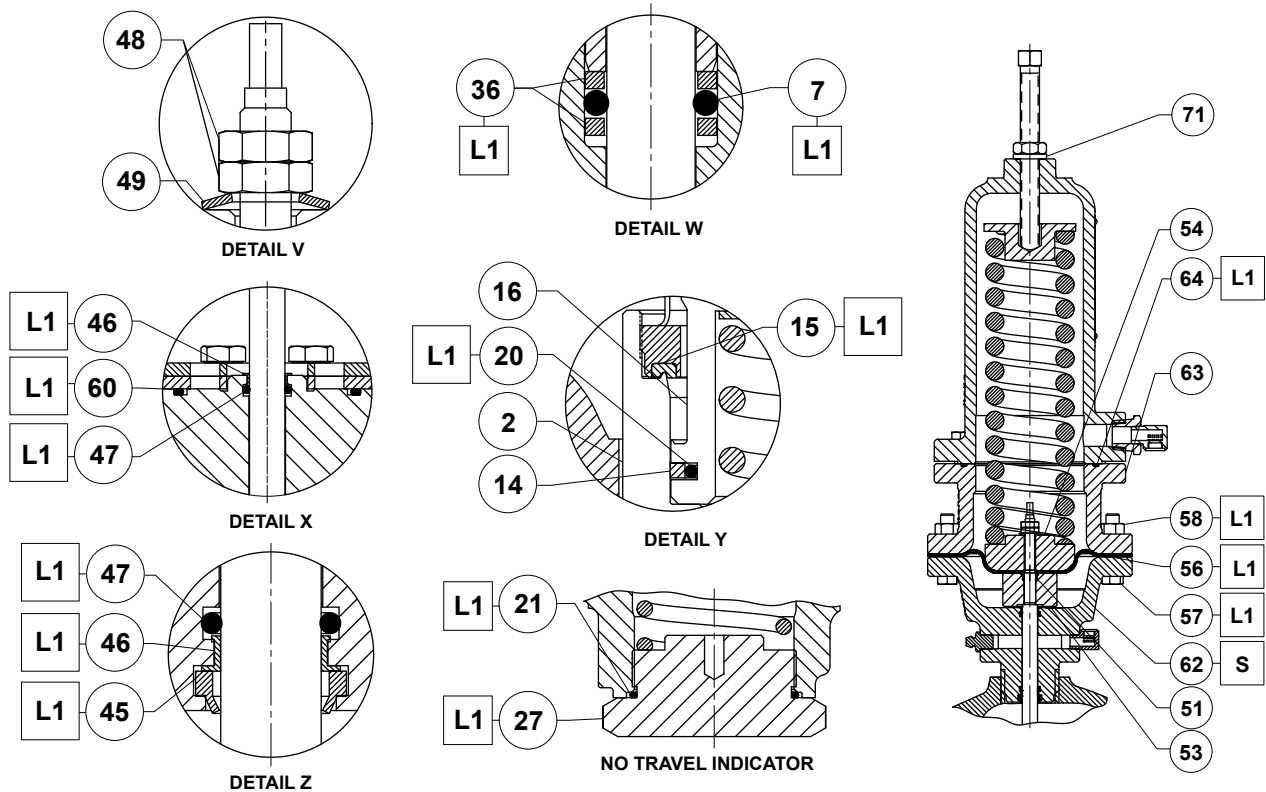

GE38435

□ APPLY LUBRICANT OR SEALANT<sup>(1)</sup>:  
 L1 = MULTI-PURPOSE PTFE LUBRICANT  
 S = MULTI-PURPOSE PTFE THREAD SEALANT

Note: Keys 64 and 71 are used only for pressure-loaded actuators.

1. Lubricants and sealants must be selected such that they meet the temperature requirements.

Figure 1. Type MR105 Assembly Drawings (continued)

## Industrial Regulators

### Emerson Process Management Regulator Technologies, Inc.

USA - Headquarters  
 McKinney, Texas 75070 USA  
 Tel: +1 800 558 5853  
 Outside U.S. +1 972 548 3574

Asia-Pacific  
 Shanghai 201206, China  
 Tel: +86 21 2892 9000

Europe  
 Bologna 40013, Italy  
 Tel: +39 051 419 0611

Middle East and Africa  
 Dubai, United Arab Emirates  
 Tel: +971 4811 8100

## Natural Gas Technologies

### Emerson Process Management Regulator Technologies, Inc.

USA - Headquarters  
 McKinney, Texas 75070 USA  
 Tel: +1 800 558 5853  
 Outside U.S. +1 972 548 3574

Asia-Pacific  
 Singapore 128461, Singapore  
 Tel: +65 6770 8337

Europe  
 Bologna 40013, Italy  
 Tel: +39 051 419 0611  
 Chartres 28008, France  
 Tel: +33 2 37 33 47 00

Middle East and Africa  
 Dubai, United Arab Emirates  
 Tel: +971 4811 8100

## TESCOM

### Emerson Process Management Tescom Corporation

USA - Headquarters  
 Elk River, Minnesota 55330-2445, USA  
 Tel: +1 763 241 3238  
 +1 800 447 1250

Europe  
 Selmsdorf 23923, Germany  
 Tel: +49 38823 31 287

Asia-Pacific  
 Shanghai 201206, China  
 Tel: +86 21 2892 9499

For further information visit [www.fisherregulators.com](http://www.fisherregulators.com)

The Emerson logo is a trademark and service mark of Emerson Electric Co. All other marks are the property of their prospective owners. Fisher is a mark owned by Fisher Controls International LLC, a business of Emerson Process Management.

The contents of this publication are presented for informational purposes only, and while every effort has been made to ensure their accuracy, they are not to be construed as warranties or guarantees, express or implied, regarding the products or services described herein or their use or applicability. We reserve the right to modify or improve the designs or specifications of such products at any time without notice.

Emerson Process Management Regulator Technologies, Inc. does not assume responsibility for the selection, use or maintenance of any product. Responsibility for proper selection, use and maintenance of any Emerson Process Management Regulator Technologies, Inc. product remains solely with the purchaser.