

# Fisher® DMA, DMA-AF, DMA-AF-HTC, DSA, and DVI Desuperheaters

Fisher DMA, DMA-AF, DMA-AF-HTC, DSA, and DVI desuperheaters can be used in many applications to efficiently reduce the temperature of superheated steam to the desired set point. Available variations are mechanically atomized (both fixed geometry and variable geometry) and steam assisted. Desuperheaters are available for installation in steam lines from DN25 through DN1500 (NPS 1 through 60) in diameter and are capable of maintaining steam temperatures to within 6°C (10°F) of saturation temperatures.

## Available Insertion Style Desuperheaters

- **DMA**—A simple mechanically atomized desuperheater with single or multiple, fixed-geometry spray nozzles is intended for applications with nearly constant load. The DMA is installed through a flanged connection on the side of a DN150 (NPS 6) or larger pipeline. Maximum unit  $C_v$  is 3.8.
- **DMA-AF**—A variable-geometry, mechanically atomized, back-pressure-activated desuperheater with one, two, or three spray nozzles is designed for applications requiring control over moderate load fluctuations. The DMA-AF desuperheater (figure 1) is installed through a flanged connection on the side of a DN200 (NPS 8) or larger pipeline. Maximum unit  $C_v$  is 15.0.

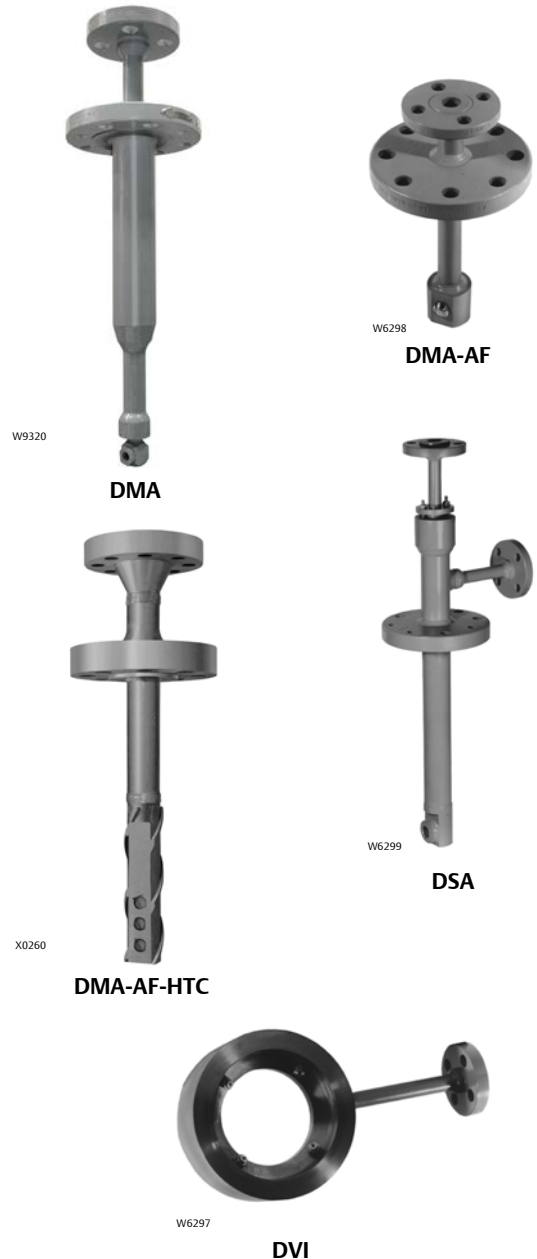

- **DMA-AF-HTC**— The DMA-AF-HTC is functionally equivalent to the DMA-AF, however it is structurally suited for severe applications. The most common applications include boiler interstage attenuation, where the desuperheater is exposed to high thermal cycling and stress, high steam velocities and flow induced vibration. In addition to this specific application, the DMA-AF-HTC is suitable for other severe desuperheating application environments. The DMA-AF-HTC uses a construction optimized to move weld joints away from high stress regions.

The desuperheater design incorporates an integral thermal liner inside the desuperheater body pipe. This minimizes the potential for thermal shock when cool water is introduced to the unit that is already heated to the operating steam temperature.

The nozzle mount for the DMA-AF-HTC is engineered to minimize the potential for excitation due to vortex shedding and flow induced vibration. The DMA-AF-HTC desuperheater (figure 3) is installed through a flanged connection on a DN200 (NPS 8) or larger pipeline. Maximum unit  $C_v$  is 15.0.

- **DSA**—The DSA desuperheater uses high-pressure steam for rapid and complete atomization of spraywater in low-velocity steam lines. This desuperheater (figure 2) is installed through a flanged connection on a DN200 (NPS 8) or larger pipeline. This desuperheater is intended for applications requiring high rangeability. Maximum unit  $C_v$  is 9.97.

## Available Ring Style Desuperheaters

- **DVI**—This desuperheater injects spraywater in the outlet of the venturi section, assuring excellent mixing and rapid atomization. The DVI desuperheater (figure 4) is easily installed between flanges in DN25 through DN600 (NPS 1 through 24) steam lines. There are no moving parts, and the water injection pattern provides rapid and thorough cooling. It is intended for applications with moderate load changes and low-velocity steam. Maximum unit  $C_v$  is 9.48.

**Specifications**

**Available Types**

■ DMA, ■ DMA-AF, ■ DMA-AF-HTC, ■ DSA, and ■ DVI (see the Available Desuperheater Types section for descriptions)

**Connections**

See table 1

**Maximum Pressure Rating<sup>(1)</sup>**

Consistent with applicable pressure-temperature ratings (as shown in table 1) per ASME B16.34

**Inherent Rangeability**

Up to 50:1. The ratio of maximum to minimum controllable  $C_v$  is dependent upon the available water pressure differential

**Spray Water Pressure Required<sup>(2)</sup>**

3.5 to 35 bar (50 to 500 psi) greater than steam line pressure

**Atomizing Steam (Design DSA)**

Atomizing steam should be at least 2.0 times the pressure of the steam to be desuperheated. Amount

of atomizing steam will be 10% of maximum spraywater flow

**Maximum Unit  $C_v$  (for Spraywater Flow)**

DMA: 3.8  
DMA-AF: 15.0  
DMA-AF-HTC: 15.0  
DSA: 9.97  
DVI: 9.48

**Construction Materials**

**Desuperheater Body (all designs except DMA-AF-HTC):** ■ Carbon steel, ■ Chrome-moly alloy steel (F22, F91), or ■ 300 series stainless steel

**Desuperheater Body (DMA-AF-HTC):** ■ Chrome-moly alloy steel (F22, F91), or ■ Carbon Steel (SA105)  
Note: NPS 3 will have body-matched cast equivalent material for nozzle mount

**Nozzle Material**

DMA: ■ 303 or ■ 316  
DMA-AF, DMA-AF-HTC, and DSA: ■ 410 stainless steel  
DVI: ■ 303 or ■ 316 stainless steel or ■ F22 venturi with drilled hole

1. Do not exceed the pressure or temperature limits in this bulletin, nor any applicable code or standard limitations.  
2. A function of required turndown and equipment selection.

**Table 1. Connection Sizes**

DESIGN	STEAM LINE SIZE, NPS	STEAM LINE CONNECTION		SPRAYWATER CONNECTION		ATOMIZING STEAM CONNECTION	
		Size, NPS	ASME Pressure Rating Raised-Face Flange <sup>(1)</sup>	Size, NPS	ASME Pressure Rating Raised-Face Flange <sup>(1)</sup>	Size, NPS	ASME Pressure Rating Raised-Face Flange <sup>(1)</sup>
DMA	6-60	3, 4, or 6	CL150 - 1500	1, 1-1/2, or 2	CL150 - 1500	N/A	N/A
DMA-AF	8-60	3 <sup>(2)</sup> , 4, or 6		1, 1-1/2, 2, 2-1/2, or 3		N/A	N/A
DMA-AF-HTC	8-60	3 or 4	CL150, 300, 600, 900, 1500, or 2500	1-1/2 <sup>(3)</sup> , or 2	CL150 - 2500	N/A	N/A
DSA	8-60	3 <sup>(2)</sup> , 4, or 6	CL150, 300, 600, 900, or 1500	1, 1-1/2, or 2	CL150 - 2500	1, 1-1/2, or 2	CL150, 300, 600, 900, or 1500
DVI	1-24	1-24	CL150 - 2500	1/2, 3/4, 1, or 2	CL150 - 2500	N/A	N/A

1. Other standard flanges and connections are also available.  
2. Consult your Emerson Process Management sales office for acceptability of NPS 3 mounting connection for size and pressure class specified.  
3. DN 40 (NPS 1-1/2) spraywater connection is only available for CL150 - 900.

## Principle of Operation

For the most efficient use of heat energy from steam, it is necessary to reduce the temperature of steam to near the saturation temperature. With steam that is at or near the saturation temperature, it is possible to recover the large amount of energy that was put into the steam when it was heated from water to steam. Desuperheating, or attemperation as it is sometimes called, is most often used to • improve thermal efficiency of heat transfer processes by using steam near saturation, • control unintentional superheat from pressure reduction of the steam, and • protect downstream equipment and piping from elevated temperatures and pressure.

The DMA, DMA-AF, DMA-AF-HTC, DSA, and DVI desuperheaters produce a spray of cooling water in a steam line (figure 5). The spraywater cools the steam to near the saturation temperature or to a custom setpoint. The rate of cooling is dependent on spraywater droplet size, distribution, and velocity. The

temperature is controlled by varying the amount of spraywater flow.

In operation, spraywater is supplied to a connection on the desuperheater. A signal from a downstream controller positions an actuator or valve to control the amount of spraywater flow for cooling. The spraywater control valve is a separate valve in the spraywater line.

In the DSA desuperheater, high pressure steam is mixed with the spraywater to produce a critical or near-critical pressure drop in the atomizing steam for a very high velocity. The high velocity disperses the spraywater into very small particles for rapid cooling.

In the DVI desuperheater, spraywater enters the desuperheater water tube. It continues into the distribution chamber and is forced into the injection orifices. Steam enters the desuperheating venturi and is accelerated to maximize the velocity at the point of water injection. The high steam velocity and turbulent steam flow improves mixing of water and steam, increasing rangeability.

**Figure 1. Fisher DMA-AF Desuperheater**

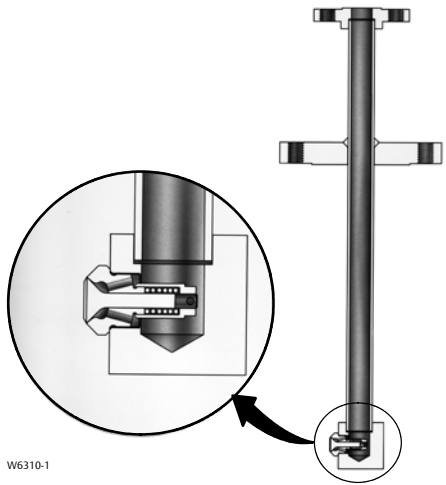

**Figure 2. Fisher DSA Desuperheater**

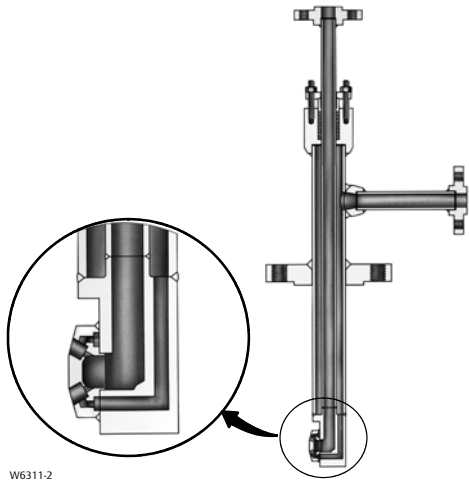

**Figure 3. Fisher DMA-AF-HTC Desuperheater**

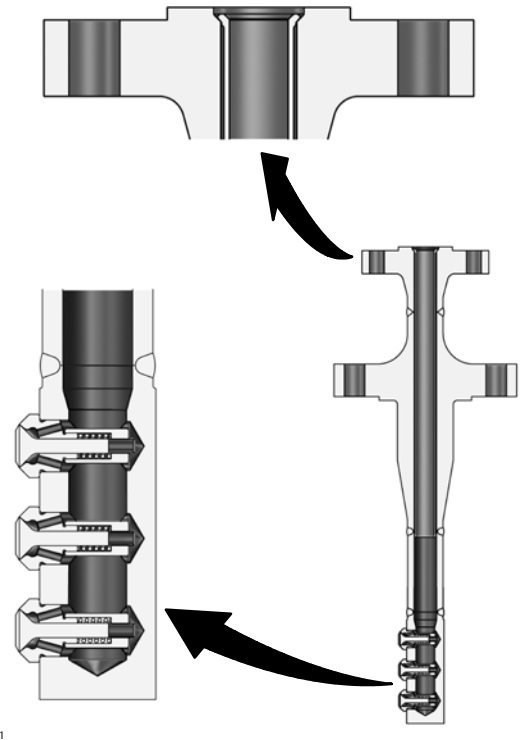

**Figure 4. Fisher DVI Desuperheater**

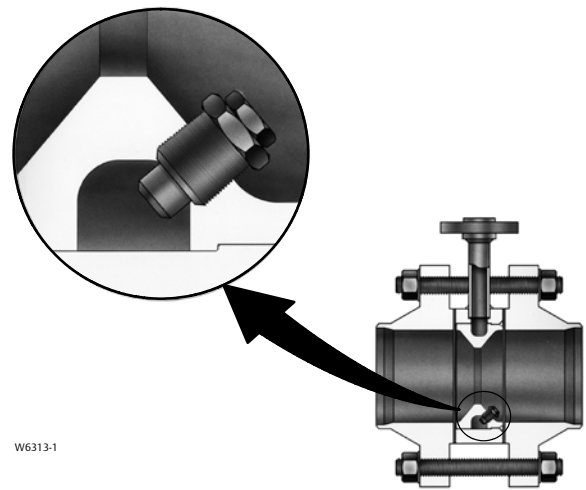
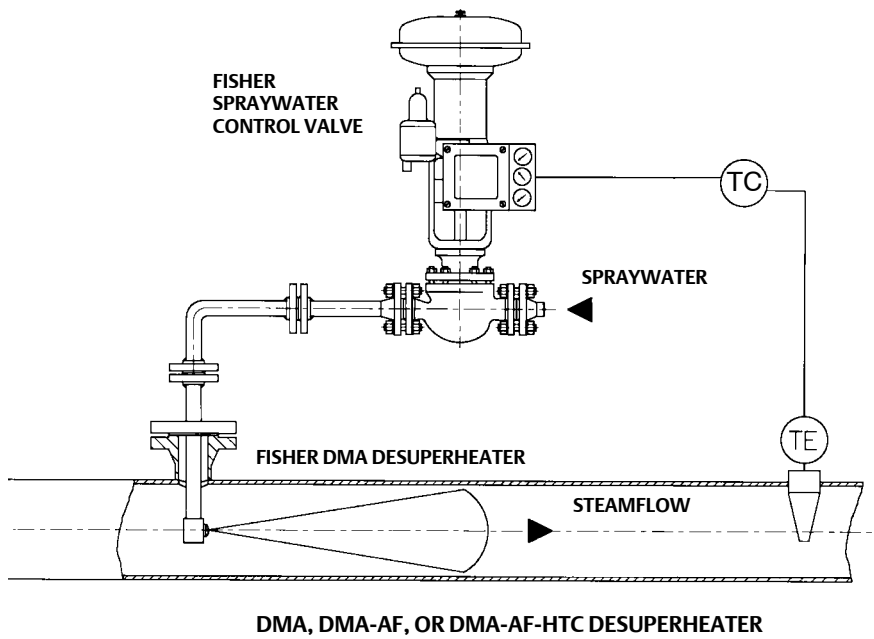
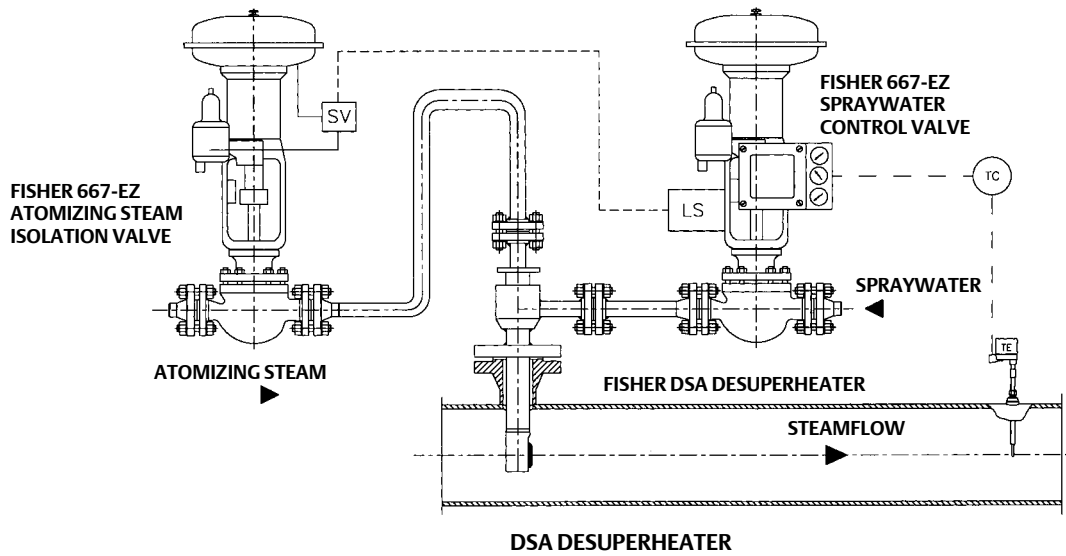
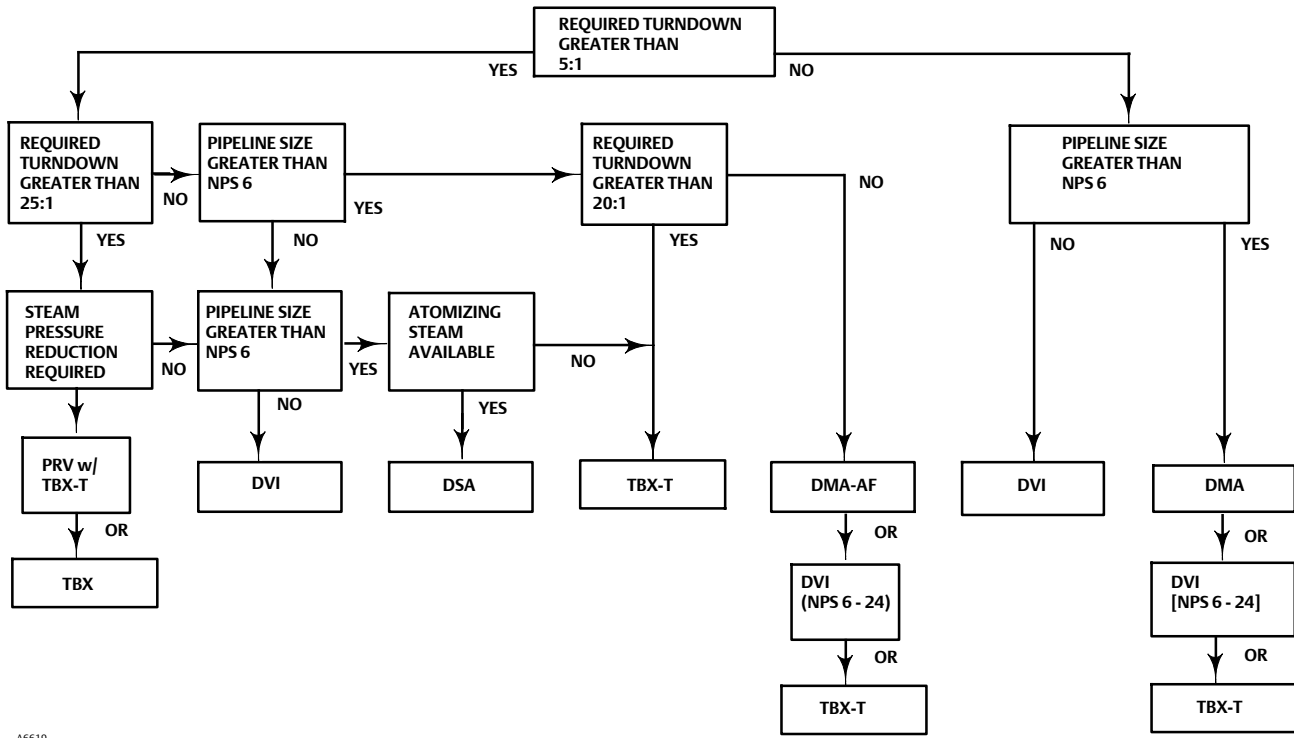

Figure 5. Typical Installation



B2317

Figure 6. Selection Flow Chart



A6619

## Ordering Information

Use the flow chart in figure 6 to select the appropriate desuperheater for your requirements. Dimensions are shown in figures 7, 8, 9, and 10.

When ordering, specify the following information. Items 1 through 6 are required for desuperheater sizing.

1. Maximum, normal, and minimum steam flow rate.
2. Steam pressure and temperature at the inlet and outlet.
3. Spraywater pressure and temperature.

4. Atomizing steam pressure and temperature (DSA desuperheater only).

5. Design conditions, if different from operating conditions.

6. Steam line size.

7. Desuperheater steam connection size, type, and rating.

8. Spraywater connection size from table 1.

9. Atomizing steam connection size from table 1 (DSA desuperheater only).

Figure 7. Fisher DMA and DMA-AF Dimensions (also see table 2)

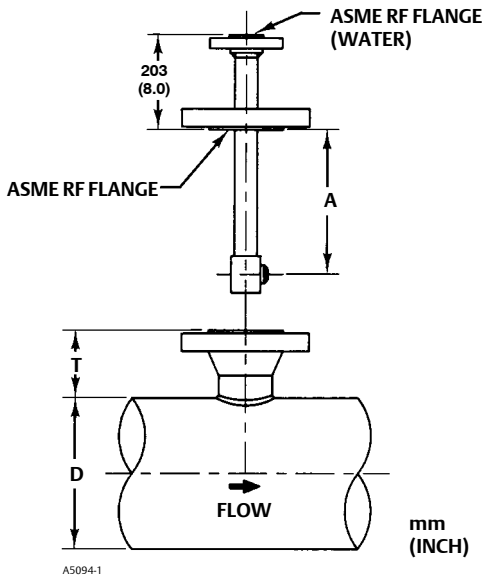

A5094-1

Table 2. Fisher DMA and DMA-AF Face-to-Face Dimensions

DIMENSION				
A		D (Nominal Pipe Size), NPS	T	
mm	Inches		mm	Inches
360	14.19	6 <sup>(1)</sup>	273	10.75
		8	248	9.75
		10	216	8.50
448	17.63	12	279	11.00
		14	267	10.50
		16	241	9.50
		18	216	8.50
524	20.63	20	267	10.50
		22	241	9.50
		24	216	8.50
		>24	216	8.50

1. DMA only.  
Note: For NPS 6 and 8 (DMA-AF only) mounting flange, add 69.6 mm (2.75 inches) to the A and T dimensions. For CL2500 mounting, consult your Emerson Process Management sales office. Refer to the certified drawing to verify the inside-diameter requirements of mounting for DMA-AF.

Table 3. Fisher DMA-AF Minimum Mounting I.D.

NOZZLE MODEL	VALVE BODY PIPE	MINIMUM BODY FLANGE	WATER FLANGE	MINIMUM MOUNTING I.D.	
	Size, NPS	Size, NPS	Size, NPS	mm	Inches
DMA - M Spray Nozzle	1	3	1, 1-1/2, or 2	73.66	2.9
DMA - A through DMA - U Spray Nozzle				58.42	2.3
DMA-AF-A,B,C			1	3	1
DMA-AF-D,E	73.66	2.9			
DMA-AF-A,B,C,D	1-1/2	4	1, 1-1/2, or 2	77.98	3.07
DMA-AF-E				80.06	3.152
DMA-AF-F				87.33	3.438
DMA-AF-G				92.05	3.624
DMA-AF-H				97.18	3.826
DMA-AF-J				6	1, 1-1/2, or 2



Figure 8. Fisher DSA Dimensions (also see table 4)

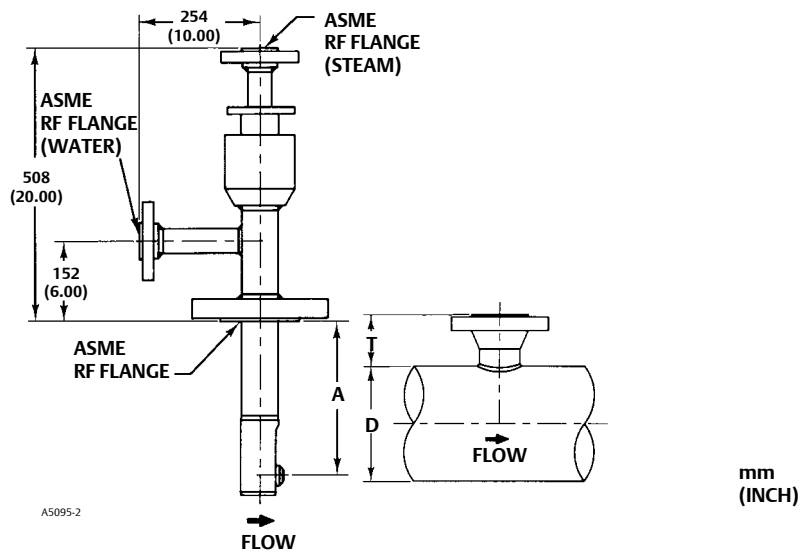

Table 4. Fisher DSA Dimensions

DIMENSION				
A		D (Nominal Pipe Size), NPS	T	
mm	Inches		mm	Inches
360	14.19	8	248	9.75
		10	216	8.50
448	17.63	12	279	11.00
		14	267	10.50
		16	241	9.50
		18	216	8.50
524	20.63	20	267	10.50
		22	241	9.50
		24	216	8.50
		>24	216	8.50

Note: For NPS 6 mounting flange, add 69.6 mm (2.75 inches) to the A and T dimensions. For CL2500 mounting, consult your Emerson Process Management sales office.

Figure 9. Fisher DVI Dimensions (also see table 5)

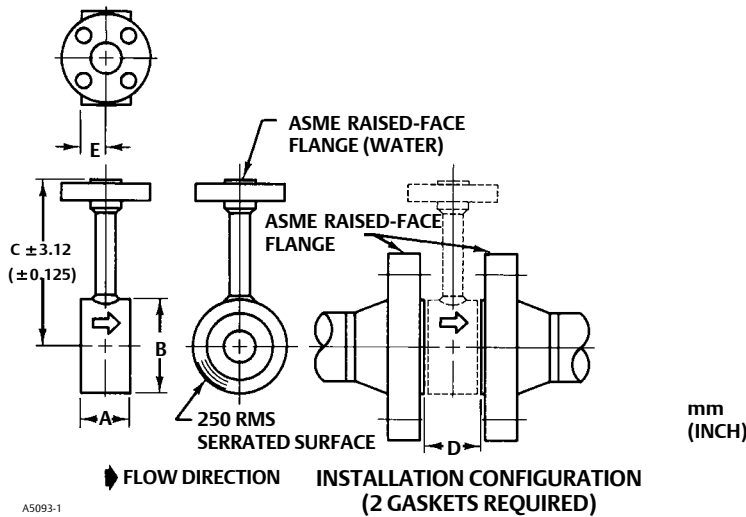
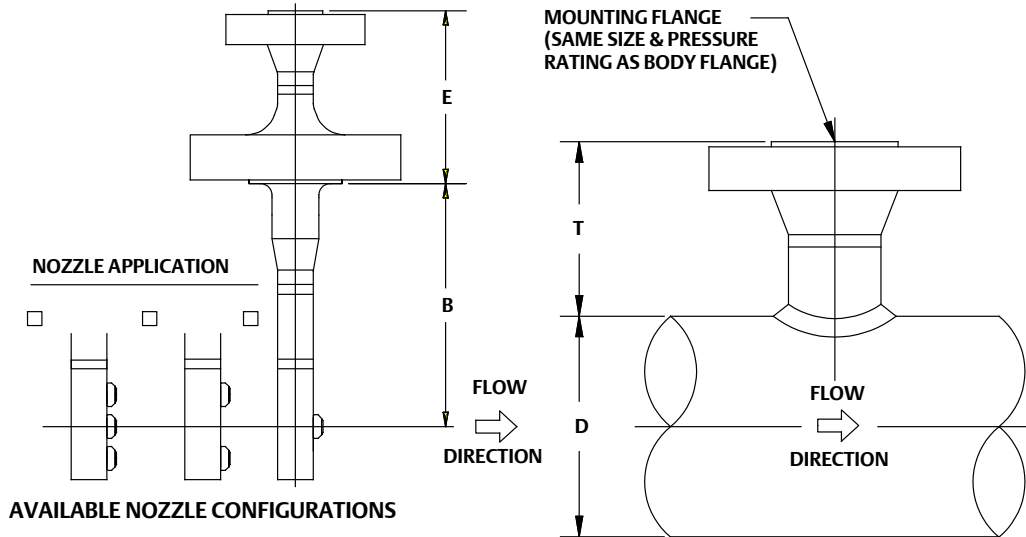

Table 5. Fisher DVI Dimensions

NOMINAL PIPE SIZE, NPS	A	B	C—WATER CONNECTION TO MATING FLANGE					D	E
			PRESSURE RATING						
			CL150	CL300	CL600	CL900	CL1500		
mm									
1	76	51	254	254	254	254	254	83	38
1-1/2	76	73	254	254	254	254	254	83	38
2	76	92	254	254	254	254	254	83	38
2-1/2	76	105	254	254	254	254	254	83	38
3	76	127	254	254	254	254	254	83	38
4	76	157	254	254	254	254	254	83	38
6	76	216	254	254	254	406	406	83	38
8	102	270	254	406	406	406	406	108	51
10	102	324	406	406	406	406	406	108	51
12	152	381	406	406	406	406	508	159	76
14	152	413	406	406	406	508	508	159	76
16	152	470	406	406	508	508	508	159	76
18	203	533	406	508	508	508	559	210	102
20	203	584	508	508	508	559	660	210	102
24	203	692	508	559	559	660	711	210	102
Inches									
1	3	2.00	10	10	10	10	10	3.25	1.50
1-1/2	3	2.88	10	10	10	10	10	3.25	1.50
2	3	3.63	10	10	10	10	10	3.25	1.50
2-1/2	3	4.13	10	10	10	10	10	3.25	1.50
3	3	5.00	10	10	10	10	10	3.25	1.50
4	3	6.19	10	10	10	10	10	3.25	1.50
6	3	8.50	10	10	10	16	16	3.25	1.50
8	4	10.63	10	16	16	16	16	4.25	2.00
10	4	12.75	16	16	16	16	16	4.25	2.00
12	6	15.00	16	16	16	16	20	6.25	3.00
14	6	16.25	16	16	16	20	20	6.25	3.00
16	6	18.50	16	16	20	20	20	6.25	3.00
18	8	21.00	16	20	20	20	22	8.25	4.00
20	8	23.00	20	20	20	22	26	8.25	4.00
24	8	27.25	20	22	22	26	28	8.25	4.00

Figure 10. Fisher DMA-AF-HTC Dimensions (also see tables 6 and 7)



GA32864-C

Table 6. Fisher DMA-AF-HTC Dimensions

WATER FLANGE		DESUPERHEATER BODY FLANGE <sup>(1)</sup>		DIMENSION	
Size, NPS	Pressure Rating	Size, NPS	Pressure Rating	E (Standard)	
				mm	Inches
1-1/2	CL150	3 or 4	CL150	203	8
	CL300	3 or 4	CL300	203	8
	CL600	3 or 4	CL600	203	8
	CL900	3 or 4	CL900	203	8
2	CL150	3 or 4	CL150	203	8
	CL300	3 or 4	CL300	203	8
	CL600	3 or 4	CL600	203	8
	CL900	3 or 4	CL900	254	10
	CL1500	3 or 4	CL1500	254	10
	CL2500	3 or 4	CL2500	292	11.5

1. The NPS 4 DMA-AF-HTC requires a 4.00 inch minimum mounting I.D. Contact your Emerson Process Management sales office for NPS 3 DMA-AF-HTC minimum mounting I.D.

Table 7. Fisher DMA-AF-HTC Installation Dimensions

DIMENSION						
D (Nominal Pipe Size)		Desuperheater Body Flange Size, NPS	B (Insertion Length)		T (Height)	
mm	NPS		mm	Inches	mm	Inches
200	8	3 or 4	356	14.00	248	9.75
250	10	3 or 4	356	14.00	216	8.5
300	12	3 or 4	444	17.50	279	11.0
350	14	3 or 4	444	17.50	267	10.5
400	16	3 or 4	444	17.50	241	9.5
450	18	3 or 4	444	17.50	216	8.5
500	20	3 or 4	444	17.50	216	8.5
550	22	3 or 4	444	17.50	216	8.5
600-900	24-36	3 or 4	444	17.50	216	8.5

**Table 8. Fisher DMA-AF-HTC Minimum Mounting I.D.**

MINIMUM BODY FLANGE	NOZZLE MODEL	WATER FLANGE	MINIMUM MOUNTING I.D.
3	DMA-AF-A,B,C	1-1/2 to 2	2.624
3	DMA-AF-D,E	1-1/2 to 2	2.9
4	DMA-AF-A through H	1-1/2 to 2	4

**Neither Emerson, Emerson Process Management, nor any of their affiliated entities assumes responsibility for the selection, use or maintenance of any product. Responsibility for proper selection, use, and maintenance of any product remains solely with the purchaser and end user.**

Fisher is a mark owned by one of the companies in the Emerson Process Management business unit of Emerson Electric Co. Emerson Process Management, Emerson, and the Emerson logo are trademarks and service marks of Emerson Electric Co. All other marks are the property of their respective owners.

The contents of this publication are presented for informational purposes only, and while every effort has been made to ensure their accuracy, they are not to be construed as warranties or guarantees, express or implied, regarding the products or services described herein or their use or applicability. All sales are governed by our terms and conditions, which are available upon request. We reserve the right to modify or improve the designs or specifications of such products at any time without notice.

**Emerson Process Management**

Marshalltown, Iowa 50158 USA  
Sorocaba, 18087 Brazil  
Chatham, Kent ME4 4QZ UK  
Dubai, United Arab Emirates  
Singapore 128461 Singapore

[www.Fisher.com](http://www.Fisher.com)

